



BIOLOGICAL MICROSCOPE

BMIC-601

INDEX

Safety notice	2
1. Structure and nomenclature	5
2. Application	8
3. Technical parameter and specification	8
4. Configuration	10
5. Assemblage	11
6. Operation	15
7. Trouble Eliminating	18
8. Care and Maintenance	21

Safety notice

1. Transportation

As microscope is a precision instrument, handle with care, avoiding impact or abrupt movement during transportation. Do not push or pull the microscope during using, otherwise the precision for image will be reduced.

1_Hold the curve and keep the microscope in balance

2_Do not hold the focusing knob, eyepiece tubes and stage as these parts are movable. Troubles maybe caused by such handles.

Do not make specimen or filters fall off.



Figure 1

2. Working Environment

As microscope is a precision instrument, improper using will make it unworkable or reduce its precision.

1_Do not expose the microscope in the sun directly

2_Temperature range is 0_-40_ and the max. humidity is 85%

3_Avoid high temperature and humidification otherwise there will be fog or mold on the lens

4_Avoid violent vibration as the vibration will reduce the image_s quality

5_Place microscope on a stable plane and keep it in balance. Keep the environment breezy and cover the microscope with the dust-cover

6_Do not place microscope in moist room to avoid short circuit. Please turn off the power supply as soon as water drop in the microscope. If there are other things unsafe come into the microscope may cause short circuit too, please stop using and contact with manufacturers

3. Focusing knob

Never turn the left and right focusing knob in the adverse direction at the same time. Do not turn the coarse focusing knob when the stage reaches max.

position. These improper operations will make focusing structure unworkable.



Never turn the left and right focusing knob in the adverse direction at the same time

Figure 2

4. Clamp

The clamps fix the microscope firmly during transportation. Please remove them before using.



Figure 3

5. Do not take the microscope apart

As it will be damaged. Such operations might have bad effect on the performance and make user get an electric shock or injured. Please contact with manufacturers if there is any problem.

6. Make sure the voltage

There is correct input voltage in the label on microscope. Make sure the voltage in your position is right. Improper input voltage may cause short circuit and fire. The microscope will be damaged. Input voltage in the label: 100-240V 50/60Hz



Figure 4

7. Use the spare parts supplied by the manufactures

The bulb, fuse and electronic cord have been assembled already in the factory and please make sure to use the spare parts of them supplied by the manufacturers. Improper bulb, fuse and electronic cord will destroy microscope and cause fire. Please make sure to use PE electronic cord when using extra-long electronic cord. Spare bulbs: 3W LED lamp

Spare fuse: 250V 1A delayed model, 5 X 20 minitype fuse

8. Mounting the bulb

Never touch the surface of bulb with your hand directly. Please use gloves or cloth material when you mount the bulb to avoid leaving fingerprints. Fingerprints or stains should be wiped off with a tissue moistened with a small amount of alcohol. The fingerprints will etch on the bulb's surface and make brightness lower and life cycle shorter.

Please make sure the bulb's touching points are Ok as it will not light or short circuit if the bulb's touching points are damaged. Insert the bulb's legs into the bulb holder firmly. The bulb will go out if its legs have not been inserted into the holder firmly. Such Operation may cause short circuit or smoking. At last, please make sure if the collector has been mounted properly.

9. Temperature for illumination

When you use the halogen bulb, there will be high temperature when the bulb is lightened, never move the collector when the bulb is lightened. Do not touch the bulb within 30 minutes after it has been gout out. Make sure the bulb has been be cooling enough time (at least 30 minutes) to avoid scald. Do not put fibre, papers and incendive things (eg. Gasoline, aether, methanol and ethanol) close to the bulb.



10. Make sure to turn off the power supply before assembling microscope, replacing bulb or fuse.

11. Observing with oil immersion

Using small amount of oil immersion is enough. The redundant oil will adhere to stage or condenser and these will reduce microscope's performance. Get rid of the redundant oil or clean the lens by using aether or pure alcohol according to this instruction. Pay attention during process as these things are incentive. The instruction you buy may not including some products mentioned in this instruction. Safety has been considered during design while users still have the possibility to be injured and the

instruction to be damaged when improper operation made. Please pay much more attention to read this instruction carefully before using and keep it properly to make sure it will be got when it is necessary.

12.

Mark	Meaning
	1.Hot surface, don' t touch with your hands
	2.Read the instruction manual carefully before operating the micuscop unproper
—	operation will cause hurt or dameger to the operator and instrumen
	3.Switch on
O	4.Switch off

13.Operating the microscope only indoor and under the additude 2000m, IP52 grads.

If the equipment is used in manner not specified by the manufacturer, the provided by the equipment may be impaired.

1. Structure and nomenclature

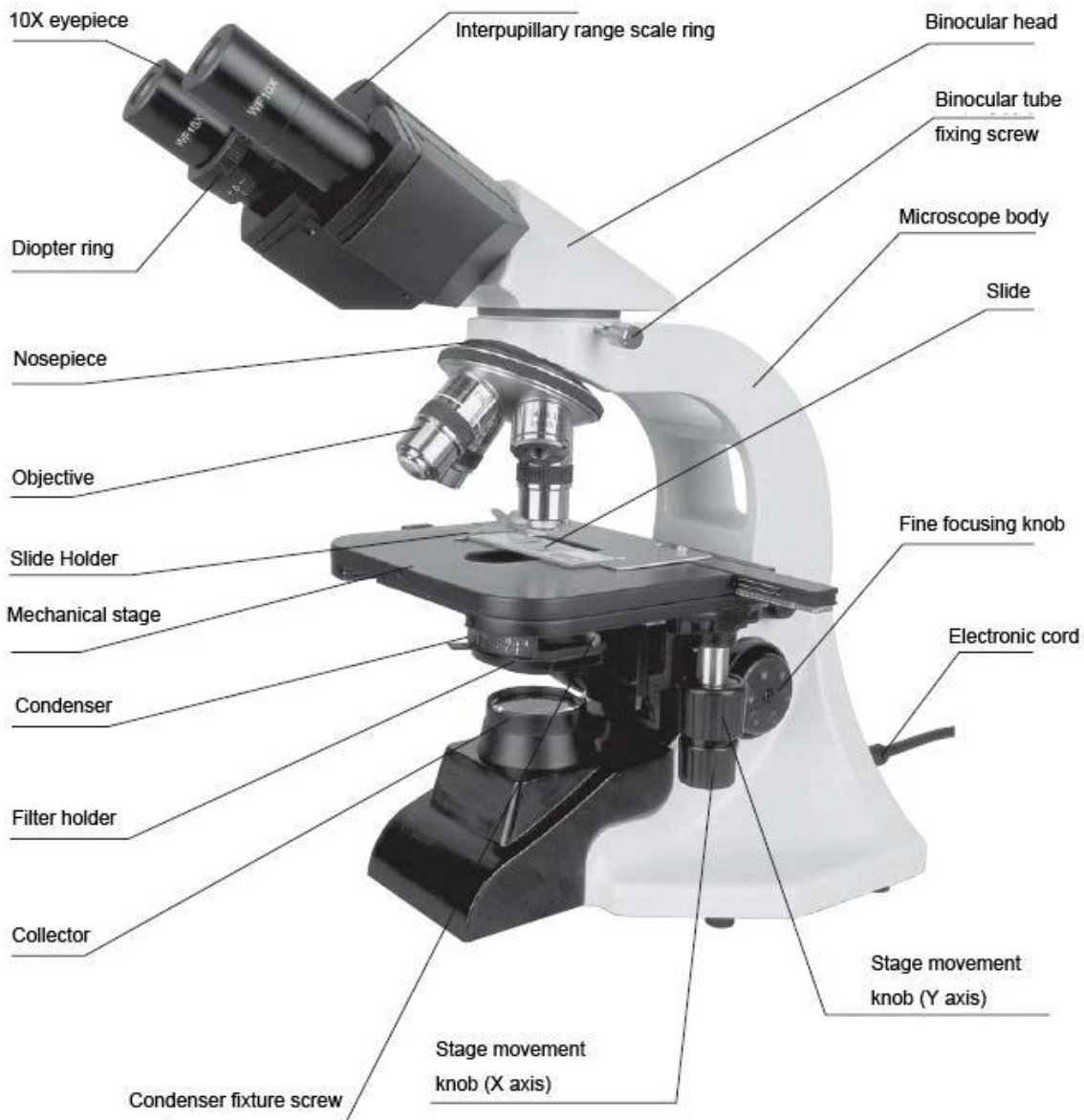

Figure 5



Figure 6

2. Application

BMIC-601 biological microscope is designed for clinical experiments and routine medical examination as well as for teaching and research purpose in biology, pharmaceutical, and bacteriology observation in medical and hygienic establishments, chemical laboratory, research institute and college, etc. This product, with modern design, good -looking appearance, adopts many advanced structure & technology in order that the clients can operate the instrument conveniently and safely. There and also following accessories can be optional for the customer: darkfield, phase contrast, photographic and video accessories.

3. Technical parameter and specification

1). Specification

1. Optical system:

Mechanical tube length: 160mm

2. Illumination: inserted transmitted illumination, 3W LED bulb(standard outfit)

Input voltage: 100V~240V 50/60Hz

Voltage undulation 10%

Rating 100V~240V 50/60Hz 0.8A

Fuse 250V 1A delayed model, 5X20 minitype fuse 2pcs

3. Focusing adjustment:

Division of fine focusing adjustment: 0.002mm

Fine focusing knob control range: stage will be up or down 0.2mm per circle

Coarse focusing knob control range: stage will be up or down 20mm

4. Mechanical stage

X-movement range: 54mm, Y-movement range: 78mm

5. Nosepiece:

Roller bear quadruple nosepiece

6. Condenser:

Abbe NA=1.25 with iris diaphragm

7. Eye tubes:

Interpupillary range 55~75mm

8. Working environment:

Temperature: 0~40°

Humidity: max. 85%, no dew

2) Optical parameter

1, Objectives: achromatic objectives

Magnification	N.A.	Cover glass thickness(mm)	W.D. (mm)	Dry/Oil
4X	0.1	0.17	26.9	Dry
10X	0.25	0.17	6.4	Dry
40X	0.65	0.17	0.6	Dry
100X	1.25	0.17	0.098	Oil

Table 1

2, Eyepiece

WF10X/18mm

Nomenclature

1)Total magnification

Total magnification = Eyepiece's magnification X objective's magnification

2)Numerical aperture (N.A.)

N.A. value will affect resolution and image's brightness, it is the leading parameter for objectives. $N.A. = n \times \sin a$

n stands for refractive index of the medium between objective and specimen or condenser (air or oil immersion)

a stands for half angle of max. aperture angle in the axis

The image will be sharper and brighter when the N.A. value is bigger

3)Resolution

Resolution can be measured by the distance value from one point to another one which could be distinguished on the object surface

$$\text{Resolution} = \lambda / (2 \times \text{N.A.})$$

λ stands for wavelength ($\lambda = 0.55 \mu\text{m}$)

4)Working distance

The distance between the object surface to the first surface of optical system when you get the sharpest image. The W.D. will become more short when the magnification for the objective is bigger.

5)Eyepiece view field

The max diameter measured when the diaphragm is open. 10X/18 means the magnification is 10X and the max diameter of view field is 18mm

6)Effective view field

Liner view field which is observed on the object surface

Effective view field = eyepiece view field / objective's magnification

7)Depth of field

Depth of field stands for depth of the space in which there is sharp image on the object surface.

Depth of field will be longer when the diaphragm reduces. Depth of field will be shorter when the N.A. becomes bigger.

4. Configuration

Item	Content	Piece
1	Microscope_s body (including stage, nosepiece, coaxial coarse and fine focusing adjustment, bracket for condenser, adjusting power supply, LED bulb and normal collector)	1 set
2	Siedentopf Binocular	1 pc
3	Condenser (with iris diaphragm, without auxiliary lens)	1 pc
4	Objectives(achromatic objectives)4X10X40X100X	1 set
5	WF10X eyepiece	2 pcs
6	Blue filter	1 pc
7	Electronic cord	1 pc
8	Immersion oil	1 bottle
9	Dust cover	1 pc
10	Instruction	1 pc
11	Wrench 2.5, 1.5	1 set

Table 2

Optional

Item	Content
------	---------

1	Collector with iris diaphragm
2	Darkfield condenser
3	WF10X eyepiece with reticle
4	WF15X eyepiece
5	Plan objectives (4X, 10X, 40X, 100X)
6	12V 20W halogen illumination
7	Trinocular head
8	0.5X CCD camera adapter

Table 3

5. Assemblage

Please read the safety notice carefully before assembly and make the assembly according to the following steps.

Tools: wrench (2 pcs)

1. Checking the input voltage

There is correct input voltage in the label on microscope. Make sure the voltage in your position is right. Improper input voltage may cause short circuit and fire. The microscope will be damaged. Turn off the power supply (turn the switch to O) and insert one end of the electronic cord (connector) into the entrance for AC. Insert the other end of the electronic cord (pin) into the grounded AC connector and make sure that the electronic cord has been connected safely

_ Please use the supplied electronic cord by manufacturer

_ Please make sure to use PE electronic cord when using extra-long electronic cord.

_ Pay attention that the microscope should be placed near AC connector and the AC connector is touchable for users



Figure 7

2. Removing the clamps for transportation

The clamps fix the stage and focusing adjustment firmly during transportation. Handle the grooves beside collector and pull it out. Remove the clamps by wrenches.

_ Mechanical stage

There is one clamp fixing the mechanical stage in Y axis direction. Remove the bolts and clamps.

_ Focusing adjustment

Pull out the collector. The bracket is fixed by one clamp. Please remove the bolts and clamps.



Figure 8

3. Mount the binocular head

Loosen the fixing screw in the eye tubes and insert the binocular head into the eye tubes. Then tighten the screw.

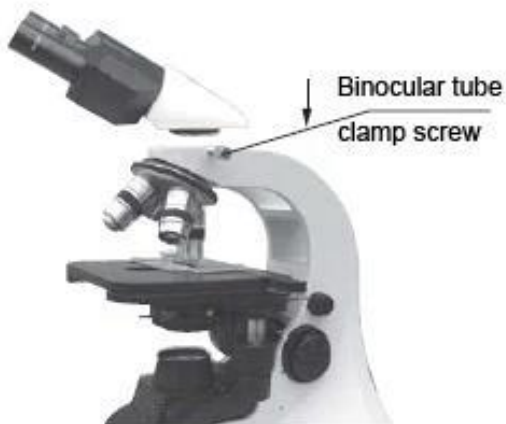

Figure 9

4. Mount the blue filter

Take out the filter from the bottom of condenser and mount it in the bracket then move the bracket into the condenser.



Figure 10

5. Adjustment and replacement

1_Condenser

The condenser is mounted in the microscope before shipment. Remove or replace the condenser according to the following steps

- a. Handle the grooves of the condenser and pull it out
- b. Turn the lifting knob for condenser and make the bracket in a suitable position
- c. Loosen the screw in the left side of condenser and take out the condenser. Mount the blue filter in the bracket then move it into the bottom of the condenser. Make the label in the condenser forward and move the condenser into the bracket. At last tighten the screw.
- d. Handle the grooves and push the condenser in.
- e. Turn the lifting knob of condenser and make the condenser to the highest position.
- f. Turn the lifting knob of condenser and make the condenser a lit bit lower. The image will be focused in the right place of object (center of light path) when the light transit condenser. Move the condenser up and down a little to make the dispersion image disappeared.



Figure 11

2_Objectives

The objectives have been mounted in the microscope before shipment

Take off the specimen from the stage and make the stage lower when you replace the objectives. Handle the objective with your two hands and remove it. Be carefully do not make it fall off. Turn the nosepiece to get the objective you need. The magnification for the objectives become bigger in clockwise direction (observing from the top of the microscope).

3_Specimen clip

The clip has been mounted in the stage before shipment

Loosen two screws by wrenches supplied by manufacturer to remove the clip.

4_Eyepieces

10X eyepieces have been in the foam box before shipment. Insert the eyepiece into the eyepiece tubes and tighten the fixing screws by wrench

5_ Other attachments

Replace other attachments (eg, camera) according to the instruction

6. Replacement

1_ Replacement for bulb (halogen bulb, optional)

Turn off the power supply (turn the switch to _O_) and pull out the connector

Wait for 30 minutes till the bulb is cooling

Handle the grooves in condenser and pull it out

Pull out the original bulb

Replace the bulb by gloves or cloth material then insert the bulb into the socket entirely

Pull the condenser back to its original position

Connect the electronic cord to the power supply

2_ Replacement for fuse

Turn off the power supply (turn the switch to O) and pull out the connector

Open the cover for fuse by screwdriver

Mount the new fuse

Make sure that the voltage shown in the cover for fuse is same to the working voltage

Mount the cover

6. Operation

1. Illumination

Turn on the power supply (turn the switch to -) ,then the bulb will be on. The lightness can be adjusted by turning the adjusting knob.

2. Interpupillary range

Adjust the sediment of binocular to make sure that view field in the right and left eyepiece is consistent.

3. Placing the specimen

Put the specimen in the stage and make the cover glass on it. Make the clips clamp them entirely. Two slides can be put in the stage in the same time

4. Focus by 10X objective

Put the 10X objective into the optic path and focus by turning coarse and fine focusing knob

_ Turn the stage and focusing knob according to the direction shown in the picture

_ There is no coarse focusing knob in one side of stage_s moving knob and in the other side there are both coarse and fine focusing knob

_ Never turn the left and right focusing knob in the adverse direction at the same time. Never turn the coarse focusing knob when the stage is in the end of removing range. Otherwise it will make damage to the instrument

_ Detailed operation

It is difficult to do focusing if turning the focusing knob optionally. The specimen may be crushed when 100X objective is used. Please read the instruction carefully to avoid making damage to the cover glass or objective

1_ Put the 10X or 4X objective into optic path

2_ Remove the stage to the top by turning the coarse focusing knob

3_ Observe through the eyepiece and turn the coarse focusing knob slowly to let the stage down and down till there is sharp image

4_ Turn the fine focusing knob to focus finely Use the 10X objective or 4X objective firstly before 40X and

100X objective. Turn the fine focusing knob to focus finely

5. Adjusting the diopter for eyepieces

Adjust the diopter ring according to user's diopter for left and right eyes. This function could make use of advantages of objectives fully. Meanwhile it also can be react as focusing

1_Put the 40X objective in the optic path and turn the coarse and fine focusing knob to do focusing

2_Put the 10X objective (or 4X objective) in the optic path

3_Let your left eye observe through the left eyepiece and do focusing by the diopter adjusting ring in left eyepiece

4_Repeat the above steps till sharp image can be observed by left and right eyepiece at the same time.

6. Adjusting the upright position for condenser

Turn the lifting knob for condenser till it reaches the top position then fall it a little bit down. If there is dispersion image in the view field, please remove the condenser a little bit of up and down to make the dispersion image disappeared

7. Objectives

Turn the nosepiece to choose the objective and adjust the view field diaphragm and aperture accordingly

8. View field diaphragm

Adjust the view field diaphragm according to the objective till it_ image touches the edge of view field as this could eliminate the outside light and increase the contrast of the image.

Notice: There will no image for view field diaphragm when 100X objective is used. So adjust the diaphragm to it's min diameter

Centering view field diaphragm

1_Use the 10X objective and focus the image. Turn the view field diaphragm adjusting ring with ershins and reduce the diaphragm's diameter

_Turn the lifting knob for condenser to focus the image of view field diaphragm

_Turn the two centering screws for condenser and make the image in the center of view field

_Check the centering and open the view field diaphragm till the image of the diaphragm touches the edge of view field. Please do the centering again if the image of the diaphragm doesn_t touch the edge of view field

_Open the view field diaphragm and make its image a little bigger than the view field in practice

9. Adjusting aperture diaphragm

Adjust the aperture diaphragm adjusting shaft for condenser till the position which stands for the magnification of objective

_ adjusting the aperture diaphragm

1_Adjust the aperture diaphragm by the adjusting shaft. The brightness and resolution will be decrease while the contrast and depth of view will increase if the diameter of aperture diaphragm reduces

2_Adjust the value of aperture diaphragm to 70%-80% of the value of objective_s N.A.

3_The aperture diaphragm could control the N.A. of condenser. Do not adjusting the brightness by it while use the brightness adjusting knob to make the adjustment

4_N.A. is marked in each objective

e.g. 40X/0.65 stands for that magnification is 40X and N.A. is 0.65

5_Remove the eyepiece and observe through the eye tubes by eyes directly N.A. of condenser could tell users the position of aperture diaphragm adjusting shaft in corresponding magnification. (That is to say, the value of aperture diaphragm should be 70% to 80% of the N.A. of objective when the aperture diaphragm adjusting shaft reaches some position) If the objective has been changed, please move the shaft to the position with the same value which is in the objective in the optic path and this will make ideal contrast

10. Observing with oil immersion

There is_ oil_ marked in the oil immersion objective. Please use the oil immersion supplied by the

manufacturer between the objective and cover glass.

1_Operation

Condenser_

Remove the slide back and fall the condenser down a little.

One drop of oil could be placed in the top of condenser by through the long aperture of stage.

Then move the slide forward and lift the condenser up

Objectives_

Turn the nosepiece and take the objective out of the optic path. Place one drop of oil on the slide then turn the condenser slowly and mount the objective.

2_Air bubble in oil immersion

a) Never make the oil immersion into your eyes. Please take following steps as soon as the oil immersion touches your skin or eyes.

Use soap or clean water to wash your skin carefully.

Please wash your eyes with clean water (at least wash 15 minutes) and go to the hospital at once.

b) Do not expose the oil immersion in the sun or ultraviolet radiation directly.

As the air bubble in the oil immersion will make bad affect to the quality of image, please make sure that there is no air bubble in the oil immersion before use. Please check the air bubble as following, remove the eyepieces and open the view field diaphragm and aperture diaphragm entirely then observe the exit pupil which is light and in nummular shape.

c) Remove the air bubble as following.

Turn the nosepiece slowly and turn the oil immersion objective once or twice.

Turn the lifting knob for condenser slowly and make the condenser a little bit of up and down.

Increase the amount of oil immersion or change the old oil immersion with new one

3_Operation for oil immersion

Use the oil immersion as little as possible. The oil immersion will be conglutinated to the stage and condenser and this will have bad effect the performance if there is too much oil immersion. Please clean the redundant oil on the objective and condenser after finishing the observation otherwise the image will be affected. Use the aether to clean the oil then use the pure alcohol (ethanol or carbinol) to make entirely cleaning. Please repeat the clean three or four times.

_ Notice:

Please follow the instruction from manufactures when the aether or pure alcohol is used.

Keep them away from the fire or electronic spark

4_Attention

_ Keep the bottle for oil immersion sealed as much as possible and check it periodically

_ Never press the bottle overly as it may caused oil gushed out of the bottle

_ Clean the out surface of the bottle from remanent oil

11.Adjusting the coarse focusing knob's tension

The tension of coarse focusing knob is adjustable. Please turn the tension controlling ring of the coarse focusing knob clockwise then the tension will be increased. This ring is near the coarse focusing knob. If you want decrease the tension, please turn the ring with ershins. The stage will fall down automatically if the tension of the ring decreased too much.

7. Trouble Eliminating

If difficulties should be encountered in the course of operation, and no major instrument mal functions can initially be detected, please recheck the symptoms, referring to the tables provided below, before contacting the service department representative.

1. Optical

Symptoms	Cause	Countermeasures	
Darkness at the periphery, or uneven viewfield brightness	Revolving nosepiece not in click stop position (objective not centered in optical path)	Revolve to click-stop position (switch the objective correctly into the optical path)	
	Filament image not in center	Centering	
	Dirt or dust on the lens (condenser, objective, eyepiece, collector)	Clearing	
Dirt or dust in the viewfield	Dirt or dust on the lens (condenser, objective, eyepiece, collector)	Clearing	
	Dirt or dust on the slide	Clearing	
	Condenser position too low	Correct position	
Poor image quality (low resolution poor contrast)	No cover glass on the specimen	Attach cover glass	
	Cover glass too thick or thin	Use cover glass of specified thickness (0.17mm)	
	Slide upside-down	Turn over the slide	
	Immersion oil on dry objective (especially 40X)	Clearing	
	Dirt or dust on the lens (condenser, objective, eyepiece, collector)	Clearing	
	No immersion oil used on immersion objective	Use immersion oil	
	Air bubbles in immersion oil	Remove air bubbles	
	Unspecified immersion oil used	Use specified immersion oil	
	Condenser aperture and field diaphragm opened too far	Close properly	
	Dirt or dust on the entrance lens	Clearing	
Image shifts on one side	Revolving nosepiece not in click stop position	Adjust the nosepiece and centering	
	Floating specimen	Fasten securely	
	Image shifts during focus	Specimen rise from stage surface	Place it stable
		Revolving nosepiece not in click stop position	Revolve to click-stop position
Image tinged yellow	Blue filter not used	Use blue filter	
Insufficient illumination brightness	Condenser aperture too small	Readjust aperture	
	Condenser position too low	Correct positioning	
	Dirt or dust on the lens (condenser, objective, eyepiece, collector)	Clearing	

2. Mechanical

Symptoms	Causes	Countermeasures
Image not focusable with high power objectives	Slide upside-down	Turn slide over
	Coverglass too thick	User coverglass of specified thickness (0.17mm)
High power objective contacts slide when changed-over from low power	Slide upside down	Turn slide over
	Coverglass too thick	User coverglass of specified thickness (0.17mm)
Specimen movement unsmooth	Mechanical stage not securely fastened	Tighten all fastener
Binocular images not integrated	Interpupillary distance not correctly adjusted	Adjustment
Excessive eye fatigue	Incorrect diopter adjustment	Correct adjustment
	Inadequate brightness or illumination	Adjust brightness with control dial

3. Electrical

Symptoms	Causes	Countermeasures
Lamp does not light when switched ON.	No electrical power	Check power cord connection
	Lamp bulb not inserted	Insert correctly
	Lamp failure	Replacement
Sudden lamp failure	Unspecified lamp bulb used or input voltage too high	Replace with specified lamp bulb. If the same symptom occurs after replacing the lamp, contact your dealer
Insufficient illumination brightness	Unspecified lamp bulb used	Replace with specified lamp bulb
	Voltage too low	Increase brightness with control dial
Flickering, or unstable lamp brightness	Lamp bulb about to fail	Replacement
	Lamp bulb not correctly inserted into socket	Check for positive connection

8. Care and Maintenance

1. Cleaning Lenses

Dust is best removed with a soft brush or gauze.

More persistent dirt, such as fingerprints, grease and oil, may be removed with soft cotton, lens tissue, or gauze lightly moistened with absolute alcohol (ethyl or methy alcohol).

To clean immersion oil off the oil-immersion type objective, use lens tissue, soft cotton or gauze lightly moistened with petroleum benzine only.

Do not use petroleum benzine to clean the entrance lens at the bottom of the eyepiece tube or prism surfaces inside the eyepiece tube.

Absolute alcohol and petroleum benzine are quite inflammable. Take great care when handling them and when setting the power switch on and off. Be very careful with fire.

2. Cleaning painted or plastic surfaces

Avoid use of and organic solvents (such as alcohol, ether, thinner, ect.) to clean the painted or plastic surfaces of the instrument. We recommend the use of silicon cloth.

More persistent dirt may be cleaned with mild detergent solution.

Printed plastic surfaces should be cleaned only by soft cloth moistened with water.

3. When not in use

When the microscope is not in use, cover it up with dust cover, and store in a dry place not subject to mold.

We especially recommend that the objectives and eyepieces be kept in a container(such as a desecrator).

4. Periodical inspection

To maintain the performance of the microscope, periodical inspection is recommended.



Biolab Scientific Ltd.

Trillium Executive Center, East Tower, 675 Cochrane Dr, Markham, Ontario L3R 0B8, Canada
Email: info@biolabscientific.com | Website: www.biolabscientific.com