



HORIZONTAL LAMINAR AIRFLOW

BEM1BB1

INDEX

1 Product Introduction	2
1.1 Product Description	2
1.2 Product Features	3
1.3 Technical Parameters	3
1.4 Product Structure	4
2 Installation	6
2.1 Installation Environment	6
2.2 Location Selection	7
2.3 Installation Steps	7
2.4 Check after Installation	9
3 Operating Instruction	10
3.1 Main Screen Introduction	10
3.2 Settings Interface	11
3.3 Introduction to the Usage Process	13
4 Maintenance	14
4.1 Comprehensive Maintenance Cycle	14
4.2 Maintenance and Repair Methods	15
5 Handling of Common Problems	16
6. Simple Parts Replacement	18
6.1 Replace the Fuse	18
6.2 Replace the UV Lamp	19
6.3 Replace the LED Lamp	20
7. Precautions	21
7.1 Storage Conditions	21
7.2 Transportation Conditions	21
7.3 Cautions	22
8. Label Description	23
9. Warranty	24

1 Product Introduction

1.1 Product Description

There are strict requirements for the cleanliness of the air in the work area including laboratories, electronic technology, aerospace, precision equipments and other fields at present. And clean air technology is also required in biological fields such as medicine and health, biopharmaceuticals, food, medical science experiments, sterile microorganisms, etc. Laminar Flow Cabinet is an ideal local air purification equipment to improve the clean working environment. The cleanliness of the Laminar Flow Cabinet work area can reach ISO class 5, which can effectively improve the process conditions, ensure the accuracy of products and provide a sterile environment in the fields of scientific experiments and biological experiments.

1.2 Product Features

1.2.1 Classification

Horizontal laminar flow, single-sided operation.

1.2.2 Structure

- 1) The surface of the cabinet is electrostatic sprayed, and 1.2mm cold-rolled steel plate and welded structure are used to enhance the structural strength and stability of the cabinet.
- 2) The work surface is made of stainless steel, which is beautiful and corrosion-resistant.
- 3) The bracket is made of metal with electrostatic spraying on the surface.
- 4) Control panel adopt touch switch to make the cabinet appearance beautiful and easy to operate.

1.2.3 UV sterilization

This Laminar Flow Cabinet using UV-C type 254nm wavelength UV sterilization, which can not only kill the active cells of microorganisms, but also kill strong heat-resistant budding spores and other mold spores, in addition that phage and viruses can quickly break under UV rays.

1.3 Technical Parameters

Type	BKCB-H1300	BKCB-H1800
Dimension (W*D*H)	1300*820*1780mm	1800*800*1930mm
Work area size (W*D*H)	1200*500*570mm	1700*500*730mm
Air flow type	Horizontal flow	
Work surface height	760mm	750mm
HEPA filter	HEPA without partitions, with 99.995% filtration efficiency for $\phi 0.3\mu\text{m}$ particles.	
HEPA specification	1130*515*69mm	1620 *665*69mm
Noise	$\leq 65\text{dB(A)}$	
Illumination	$\geq 300\text{ lx}$	
Vibration	$\leq 5\mu\text{m(rms)}$	

Temperature rise	≤8°C	
Display	LCD (Liquid Crystal Display)	
Splash-proof socket	The power of the equipment used does not exceed 500W.	
Grounding resistance	≤0.1Ω	
Power supply	AC220V,50 Hz(Standard) AC110V, 60Hz (Optional)	
Work area	304 brushed stainless steel	
Cabinet	The cabinet is made of 1.2mm (1mm) thick cold-rolled steel plate and the surface is electrostatically sprayed.	
UV Lamp appointed timing	UV lamp delayed 10s open to protect the safety of the operator.	
UV Lamp	30W	40W
LED lamp	8W	16W
Airflow velocity	0.2-0.45m/s	0.2-0.45m/s
Safety	Colony forming unit ≤0.5CFU/30min	
Startup password	Default 1000	

Table 1

1.4 Product Structure

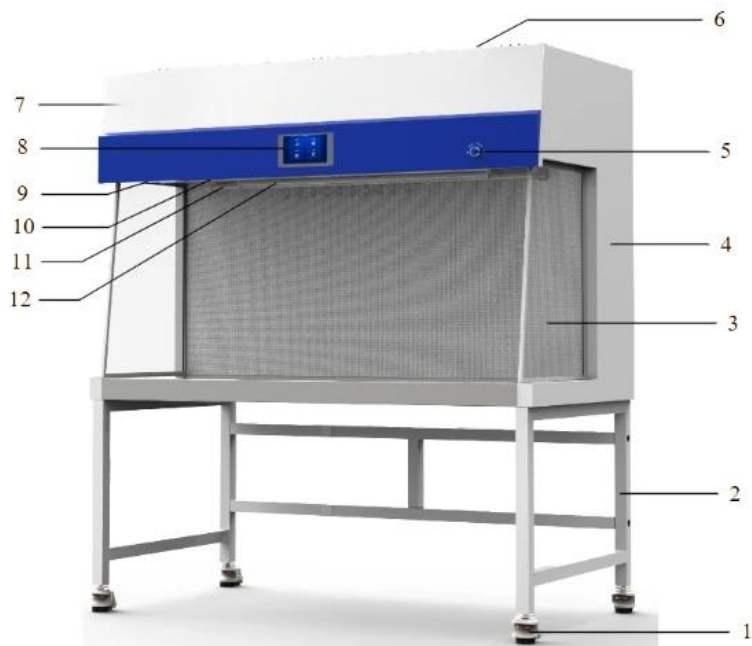

Figure 1

1	Footmaster caster	2	Base stand	3	Side window
4	Upper cabinet	5	Button switch	6	Power socket
7	Control panel	8	LED screen	9	Waterproof socket

10	LED lamp	11	UV lamp	12	Hook hanger
----	----------	----	---------	----	-------------

Table 2



Caution

- The power of the cabinet used on the receptacle should not exceed 500W (rated voltage * rated current 220V * 2.3A).
- The waterproof receptacle as waterproof only when its front cover is lay down; the receptacle cannot be considered as waterproof when the front cover is opened.

Note: IP44 is the socket degree of protection. According to IEC 60529: Protected the inside of the socket against foreign solid objects of 1.0mmΦ and greater from contacting the internal parts; protected the socket against splashing water from all directions from causing damage.

2 Installation



Caution

This Laminar Flow Cabinet needs to be installed by our trained and qualified engineers.

1. Remove all packaging components.
2. Inspect the external surface of the host for scratches, deformations or foreign objects.
3. Carefully inventory accessories and information according to the packing list in the manual.
4. Move the entire cabinet to a position as close as possible to the final location and easy to install.



Caution

When handling the Laminar Flow Cabinet, it is strictly forbidden to place or disassemble it upside down.

2.1 Installation Environment

- a. Indoor use.
- b. Humidity: ≤80%.
- c. Power supply voltage: AC 220V(Standard) AC 110V(Optional).
- d. Transient overvoltage: Facility category (overvoltage category) II.
- e. Rated pollution level: Class 2.

2.2 Location Selection

Laminar Flow Cabinet should be installed in the clean laboratory or indoor environment away from the dust source and vibration source, not at the channel. If the laboratory has windows, it should always be in the closed state. Laminar Flow Cabinet should not be placed in the circulation air entrance, so that the air can blow over the former operation area or blow to the HEPA.

If space allows, there should be 30cm space behind and around the Laminar Flow Cabinet for cleaning, if not, there should be minimum 8cm per side and 3.8cm space at the back.

The Laminar Flow Cabinet power outlet can be closed to facilitate the maintenance, and there is no need to move the device to ensure electrical safety.

The power outlet can be closed to facilitate the maintenance, and the safety of electrical appliances can be ensured without moving. Do not place the device in a position where it is difficult to disconnect the

power supply.

2.3 Installation Steps

- a. After moving to the designated indoor location, remove the packing material, check the device and accessories according to the packing list to make sure there is no damage during transportation.
- b. Assemble and place the base stand

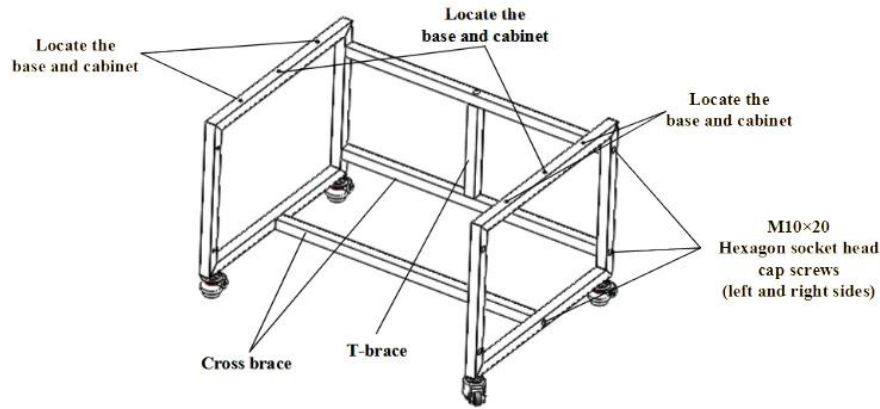

Figure 2

Screw out the M10x55 hexagon socket head cap screws in the cross brace and T brace, assemble the base tightly and firmly refer to the above figure.

- c. Connect the upper cabinet and stand base.

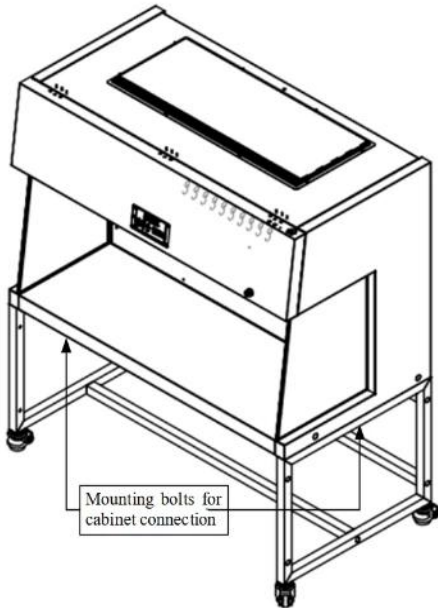

Figure 3

According to the above diagram, use M10x55 hexagon socket head cap screws, flat washers $\Phi 10$, spring washers $\Phi 10$ to fasten firmly through the base and side plate from the bottom up.

- d. Place the whole device

The Laminar Flow Cabinet should be placed in a protected area of airflow to prevent the airflow from ventilation system, air conditioner, door, window and personnel movement it.



Caution:

- The cabinet should be installed in a wide and more spacious space .

- When moving the cabinet, you need to cut off the power and adjust the casters first and then move slowly.

e. Caster adjustment

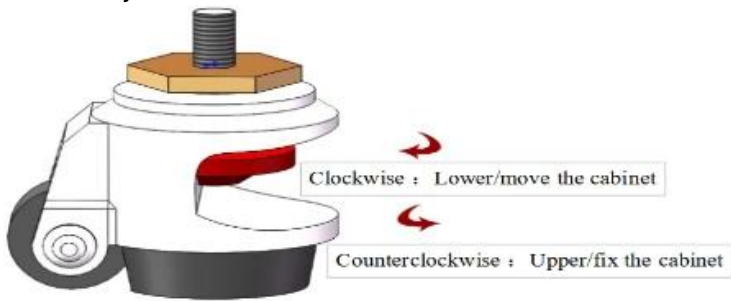

Figure 4

Rotate the red part of the caster clockwise, lower the corresponding base legs, lower the height of the cabinet, then lower four casters at the same time to move the cabinet position; counterclockwise rotate the red part of the caster, raise the corresponding base legs, raise the height of the cabinet, raise four casters at the same time to fix the cabinet; four casters can be adjusted at the same time to make the cabinet in the horizontal stable state.

2.4 Check after Installation

After powering up, check the following items according to the normal use process.

Test item	Normal condition
Normal power on-off	Connect the power supply and power on.
Fan operation	Click the "Fan" button, fan works normally.
LED lamp	Click "LED lamp" button, the LED lamp is on.
Waterproof socket	Click "Waterproof socket", output power is AC 220V(Standard) AC 110V(Optional) tested by multimeter.

Table 3

- This product is placed in laboratory sections or teaching laboratories.
- The installation location should be far away from dust and vibration sources.
- Be sure to plug the power supply into an outlet with a ground wire and ensure that the ground terminal is reliably grounded, and use a power supply with a leakage protection device.
- The interior and surroundings of the cabinet must be carefully cleaned after installation using a vacuum cleaner or a tool that does not produce fibers.
- Test the average velocity of working area with an anemometer after installation and cleaning. When the average airflow velocity is less than 0.2m/s, the airflow velocity should be increased. On the contrary, when the average airflow velocity is greater than 0.5m/s, it should be reduced.



Caution:

If there is any problem please contact your local dealer for installation adjustment.

3 Operating Instruction

3.1 Main Screen Introduction

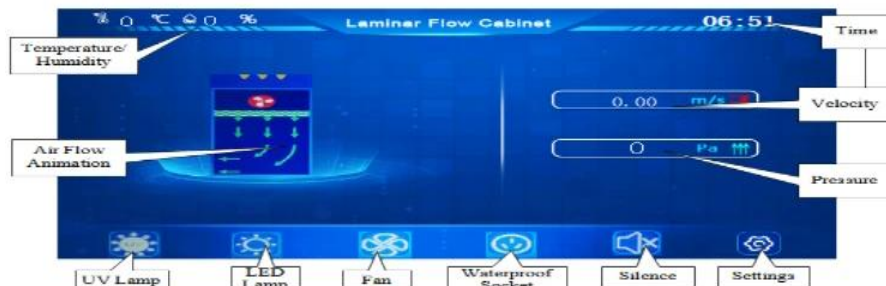

Figure 5

Home Screen

Temperature/Humidity: Real-time measurement and display of temperature and humidity in the operation area.

Air Flow Animation: When the device is running, display the air flow direction, when close the fan, the animation stops.

UV Lamp: Control the switch of UV lamp.

Note: UV lamp and LED lamp have a chain mechanism, only when the fan and LED lamp are closed can UV lamp be opened.

LED Lamp: Control the open and close of LED lamp.

Fan: Control the fan switch.

Waterproof socket: Control the power on and off of waterproof socket.

Silence: Switch sound on and off. "x" is in front of the horn when the sound is off.

Settings: After clicking "Settings", it enters the settings interface, which allows you to set the following contents: "Timing Switch", "Fan Settings", "Equipment Life", "Standby Settings".

Pressure: Real-time display of the pressure difference value before and after the filter.

Velocity: Real-time display of horizontal airflow velocity magnitude.

Time: Real-time display of the current date and time.

3.2 Settings Interface



Figure 6

Home screen

Click "Settings" to enter the settings interface, where you can configure the items shown in the image. Click "Fan Settings," enter the password 666666, and access the fan settings interface. Click "Fan Settings", enter the startup password (default 1000) to access the interface, and change the startup password. The entered value will become the new startup password.

3.2.1 Timing switch

Click "Timing Switch" in the above figure to enter the timing switch interface, click "Time Input/Display Area" to input the value to be timed, and then you can switch the timing for the corresponding time.



Figure 7
Timing switch function setting



Caution:

In order to protect users, the UV lamp is turned on with a delay of 10 seconds by default. If users have other delay needs, you can set the UV lamp to turn on at a time on this interface. Before turning on the UV lamp, the user should set the timer off on this interface. In order to achieve a good effect of air and surface disinfection, the irradiation time of the UV lamp should be ≥ 30 min.

3.2.2 Equipment life

Click "Equipment Life" to enter the equipment life display interface, which can display the UV lamp used time, the equipment used time and filter used time. If the UV lamp or filter is replaced, it is needed to reset the time. Click "Time Display Area", enter the password that which can be obtained from the manufacturer.



Caution:

If the filter needs to be replaced, please contact our customer service center or local agent.



Figure 8

Equipment life

3.2.3 Standby settings

The standby time is the time when the screen is darkened and enters the screen protection state. Click "Standby Settings" to enter the standby settings interface, click the number in the "Standby Time Display Area" to modify the standby time.



Figure 9
Standby time setting

3.3 Introduction to the Usage Process

- (1) Before the experiment: Click the UV lamp, turn on the UV lamp, disinfect for more than half an hour.
- (2) Open the fan, after running for half an hour can the experiment be started.
- (3) After the experiment, click the UV lamp, turn on the UV lamp and disinfect for more than half an hour.
- (4) After use, unplug the power supply and place it in suspension to avoid power contact with moisture and water to avoid leakage.



Caution:

- (1) When using UV lamp for disinfection, people should leave the room to protect their eyes and skin from inadvertent exposure.
- (2) The intensity of the UV lamp should be tested regularly according to the manufacturer's specifications, and it is recommended that it be replaced once a quarter if it fails to pass.

4 Maintenance

The operability and safety of this device can only be guaranteed if there are enough competent personnel and units for inspection, maintenance and repair.

4.1 Comprehensive Maintenance Cycle

Maintenance should be performed weekly, monthly, annual, or every 1000 work hours, as well as every restart.

4.2 Maintenance and Repair Methods

4.2.1 Cleaning

Under normal circumstances, cleaning only requires a small amount of household or commercial dishwashing detergent, which can be dissolved in water and wiped the dirt on the surface directly.

(1) When used for the first time or use again after long time out of use

You should first use a dry cleaning towel to remove the surface of the floating dust, after wiping with a clean towel several times, make sure that there is no dust, spray medical alcohol on the medical gauze to disinfect the work area, laminar flow plate and work surface, comprehensively. Before use, turn on the UV sterilization lamp to disinfect, 30 minutes later turn off the UV sterilization lamp and press the fan key, the fan will run.

(2) When used continuously

After using the device every day, first clear all the debris on the work surface, wipe it again with a dry and wet cleaning towel, and finally disinfect the work area, laminar flow plate and work surface with medical alcohol spray on medical gauze comprehensively and prepare for use on the next day.



Caution:

You can only spray alcohol on the medical gauze with alcohol spray, do not spray alcohol on the laminar flow plate, because the laminar flow plate has a HEPA, which can not be subject to moisture.

4.2.2 Regular maintenance

a. Daily or weekly maintenance

- Use medical alcohol to disinfect and clean the device.
- Disinfect and clean the control panel with medical alcohol.
- Use flexible cleaning agent or glass-specific cleaning agent to clean the outer surface of the device and glass.
- Check each function of the device according to the user manual.

b. Monthly maintenance

- Surface cleaning.
- Check functions of the device, disinfection of the interior of it.
- Record this maintenance.

c. Annual maintenance

- Check UV lamp and LED lamp.
- Conduct a thorough inspection of device's performance for the safety of it. The maintenance fee is paid by the user.
- Record this maintenance.



Caution:

- a. Before daily maintenance, cut off the power supply.
- b. Since the statistics of operation time will directly affect the judgment of maintenance needs, we suggest that a detailed record of operation time should be prepared when using the device for reference and inquiry.
- c. The fan must be inspected and maintained regularly.
- d. Surface cleaning: To keep the cabinet clean, please clean it regularly (at least once a week is recommended). When wiping, dip a soft cloth in soapy water and then wring it out. Do not spray any chemical reagent on the operation panel or other labels to prevent discoloration or illegible label film. Clean the outer surface of the cabinet and glass with a flexible cleaning agent or glass-specific cleaning agent for glass.

5 Handling of Common Problems

When there are doubts, suspicion of device failure in the process of use, you can first refer to the following content to troubleshoot.

Before diagnosing a fault, check whether the power supply is properly connected, the power cable is obviously damaged, the fuse is in good condition, and the button switch is on.

Fault	Position	Judgement	Solution
LED lamp light is not bright or abnormal	Lamp tube	Check whether the lamp is damaged.	If damaged, replace it.
	Circuit	Check whether the cable is in poor contact.	If yes, reconnect the cables.
	Control board	Rule out other damage.	Replace control board.
UV lamp does not light up or abnormal	Lamp holder	Check whether the lamp tube is firmly connected to the lamp holder, or the lamp holder is damaged.	If not, tighten it. If damaged, replace lamp holder.
	Lamp tube	Check whether the lamp is damaged.	If damaged, replace it.
	Ballast	Check whether the ballast is damaged.	If damaged, replace it.
	Circuit	Check whether the cable is in poor contact.	If yes, reconnect the cables.
	Control board	Rule out other damage.	Replace control board.
Fan failure	Fan	Check whether the fan is damaged.	If damaged, replace it.
	Circuit	Check whether the cable is in poor contact.	If yes, reconnect the cables.
Touch screen control is not sensitive	Circuit	Check whether the cable is in poor contact.	If yes, reconnect the cables.
	Touch screen	Rule out other damage.	Replace control board.

No power to waterproof socket	Fuse	Check whether the fuse is in good condition.	If damaged, replace it.
	Waterproof socket	Inspect waterproof socket for damage.	If damaged, replace it.
	Circuit	Check whether the cable is in poor contact.	If yes, reconnect the cable.
	Circuit board	Rule out other damage.	Replace circuit board.
Device power-off	Power supply	Power supply is not connected well.	Reconnect.
	Power cord	Check whether the power cord has obvious damage.	If damaged, replace it.
	Fuse	Check whether fuse is good.	If not, replace it.
	Transformer	Check whether transformer output is normal.	If not, replace it.
	Control board	Rule out other damage.	Replace circuit board.

Table 4



Caution:

- The operation of the above electrical components must be carried out by a qualified electrician under safe conditions (cut off the power). And other parts are not allowed to disassemble, otherwise the consequences are borne by the user.
- If there is other failure that is not in above list, or the operator can not immediately solve, please immediately notify our company's service department immediately, for your safety, please do not repair the device by yourself;
- The maintenance work of this device can only be undertaken by trained and approved technical personnel;
- If you need to order parts, please find our technical service department, please indicate the model and number of the device you purchased.

6. Simple Parts Replacement

Operation of all electrical components of the device must be carried out by a qualified electrician under safe conditions. When the device has malfunction and the operator can not immediately troubleshoot, please notify the maintenance personnel immediately. Please do not repair the device by yourself for your safety.

If you need to order parts, you can find our technical service department, inform us of the model and number of the device you have purchased.

6.1 Replace the Fuse

Socket fuse [$\Phi 5 \times 20(5A)$] is located on the right outside of the cabinet. When you replace it, first turn off the power and unplug it, use a cross screwdriver to press and screw the fuse holder counterclockwise, take off the fuse in the fuse holder and replace it with a new fuse of same specification, then press and screw the fuse holder clockwise to replace it; fire line fuse [$\Phi 5 \times 20(10A)$] is also located on the right side, use a flat-head screwdriver to remove the fuse holder and replace the fuse with a new one, then press it back.



Figure 10

6.2 Replace the UV Lamp

The product is equipped with life of UV lamp (T8, 40W) for a cumulative working time of 600 hours. We recommend that you regularly test the UV intensity in order to achieve good disinfection effect. You can use the UV intensity test card to confirm whether need to replace the UV lamp or not. When replacing, first disconnect the power supply, then remove the lamp by screwing it 90°, take out a new UV lamp of same specification, put it on the lamp holder and screw 90° in the opposite direction.

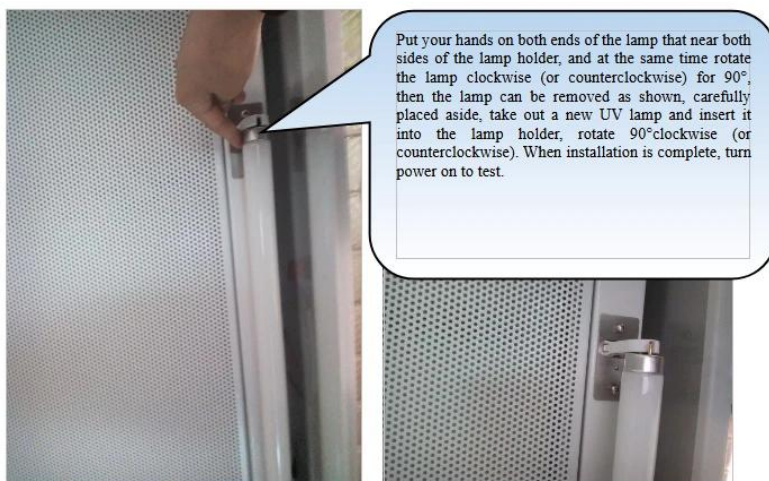

Figure 11

6.3 Replace the LED Lamp

When LED lamp needs to be replaced, please disconnect the power supply. Then tilt the LED integrated bracket to remove, unplug the right bracket connector, replace the new LED light and install back the bracket connector, and tilt the LED integrated bracket into the LED bracket slot.

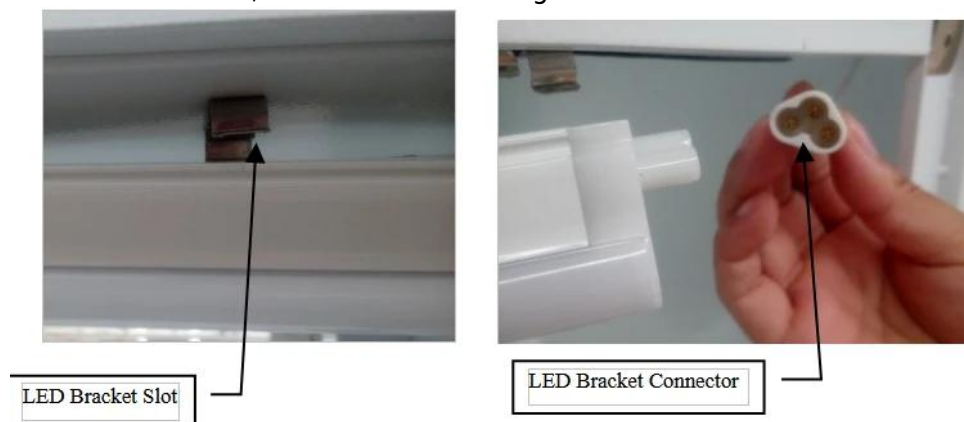

Figure 12



Caution:

- (1) It is forbidden to wipe the lamp with a wet cloth while cleaning in the powered state.
- (2) It is forbidden to do the replacement in the powered state.

7. Precautions

7.1 Storage Conditions

The device should be stored in the warehouse with relative humidity not more than 75%, temperature less than 40°C, good ventilation, no acid, alkali and other corrosive gases. The storage cycle should not exceed one year. If it stored for more than one year, the open-package inspection is needed and only passed the inspection can it be used again.

7.2 Transportation Conditions

The device should be transported in full accordance with the requirements shown on the outer surface of the packing area. The user should check the integrity of the packing area carefully when receiving the device with packing area sent by the logistics company. If the packing area has damage, extrusion and other phenomena, please refuse to sign, and contact with our company in time.



Caution:

Please contact with us in time when the Laminar Flow Cabinet that has been installed and used is relocated and moved again.

7.3 Cautions

(1) Before connecting the AC power supply, please ensure that the voltage of the power supply is consistent with input voltage and stable, ensure that the rated load of the power socket is not less than the requirements. The cabinet adopts grounding plug, which has the third leg that could only match with grounding type power socket, so it is a safety device. If the plug can not be inserted into the socket, you should ask an electrician to install a grounding type power socket. Be sure to confirm good grounding when using.

(2) During the using process of the device, do not put soft, fine items (For example: soft tissue paper) on the work surface, avoid sucking them into the negative pressure duct and fan by the inlet, which can affect the operation of the device.

(3) The maximum weight of items placed in the cabinet should not exceed 23kg/25x25cm².

(4) Avoid vibration: Avoid the use of vibrating equipments (such as centrifuges, vortex oscillators, etc.) in the cabinet, because the vibration will cause the accumulation of particulate matter on the filter membrane to shake off, resulting in a reduction in the internal cleanliness of the work area. At the same time, if the balance fails on the front work surface, it will also cause the pollution the operator.

(5) Open flame is prohibited: The use of open flame is prohibited in the cabinet. Open flame's usage will lead to flocculation of airflow in the work area, and will damage the filter. During the process of experiments that requiring high temperature sterilization, it is highly recommended to use infrared sterilizer.

(6) Service life of HEPA. With the extension of the use period, dust and bacteria accumulation in the filter will lead to the increase of HEPA pressure loss. When the increase of the velocity can not meet the requirements, you must promptly contact our service department to replace the HEPA, otherwise it will affect the safety of the device.

Replaced filter should be disposed according to the medical waste.

(7) The fan and its lower side steel plate is the plenum cover, these air ducts are strictly sealed when leave factory and needed to maintain their tightness. The operator should not loosen or remove the screws of these parts. If there is a special need, it must be handled by our service personnel.



Caution:

Solemnly declare: If the device is not used in accordance with the methods prescribed by the company, it may damage the protection provided by the device, and the company should not be responsible for the risks caused by the operation that not in accordance with the provisions!

8. Label Description



F10AL250V	10A Fuse Label
Tubular Fuse For Socket F5AL250V	5A Tubular Fuse for Socket Label
Tublar Fuse For Blower F10AL250V	10A Tubular Fuse for Blower Label
	Grounding Label
	UV Lamp Warning Label
 <p>Maximum power 500W Please use electric appliance with good grounding.</p>	Load Requirement Label
filter upstream	Filter Upstream Label

Table 5

9. Warranty

- The warranty period of the purchased product and maintenance contents are subject to the sales contract.
- In the warranty period of the device, if the user improper use caused by failure or damage, the company does not assume warranty obligations.
- Out of the warranty period, our company is also responsible for maintenance, but charged the corresponding maintenance fees.
- The service life is 8 years, production date please see product label.

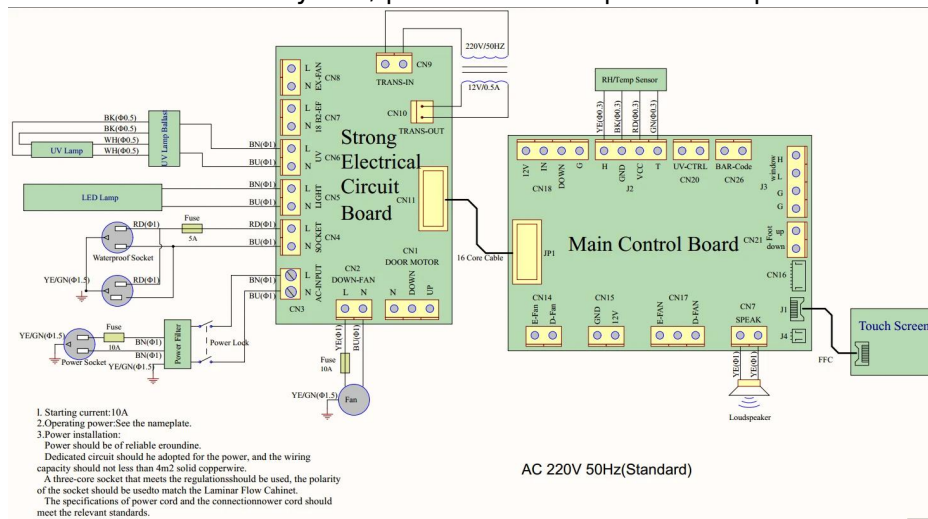

Figure 13

Appendix Wiring Schematic Diagram

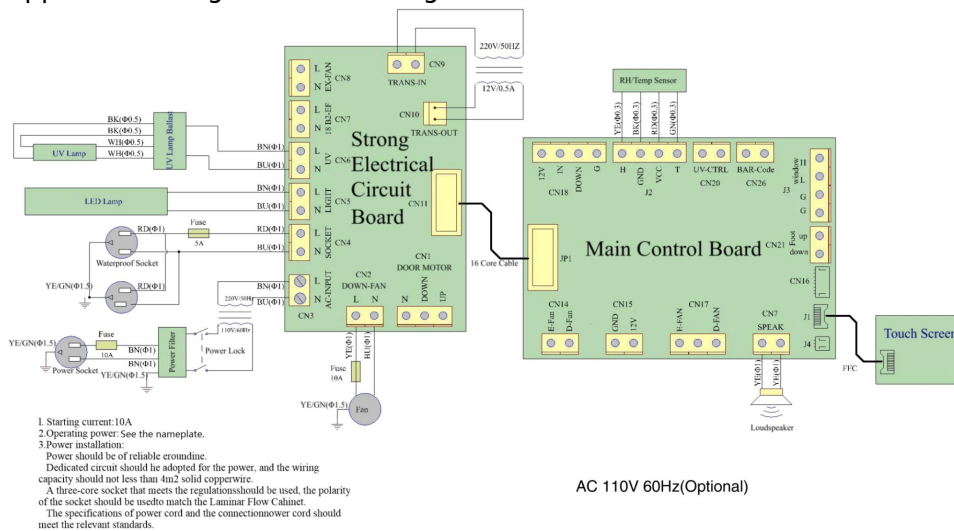

Figure 14



Biolab Scientific Ltd.

Trillium Executive Center, East Tower, 675 Cochrane Dr, Markham, Ontario L3R 0B8, Canada
Email: info@biolabscientific.com | Website: www.biolabscientific.com