

Operation Manual



BCBS-404

Biological Safety Cabinet Class II

Thank you very much for Choosing Biolab products. Please read the "Operating Instructions" and "Warranty" before operating this unit to assure proper operation.

Index

1. Unpacking, Installation, Debugging.....	03
2. User Instructions.....	14
3. Trouble Shooting and Labels.....	27
4. Warranty.....	35

01 Unpacking, Installation, Debugging

Please first check if packing box is in good condition. If the packing box is damaged, please take photos.

1.1 Unpacking

Choose the proper unpacking method according to the actual situation.

For wooden box:

1) Method 1 Necessary tools for unpacking: Electric drill with hexagon dead M8



Picture 1

2) Method 2 Use M8 Wrench to unpack



Picture 2

Rapid unpacking diagram (Picture 3). Disassemble the screws shown in the below Picture, then move the wooden pieces to right and left.

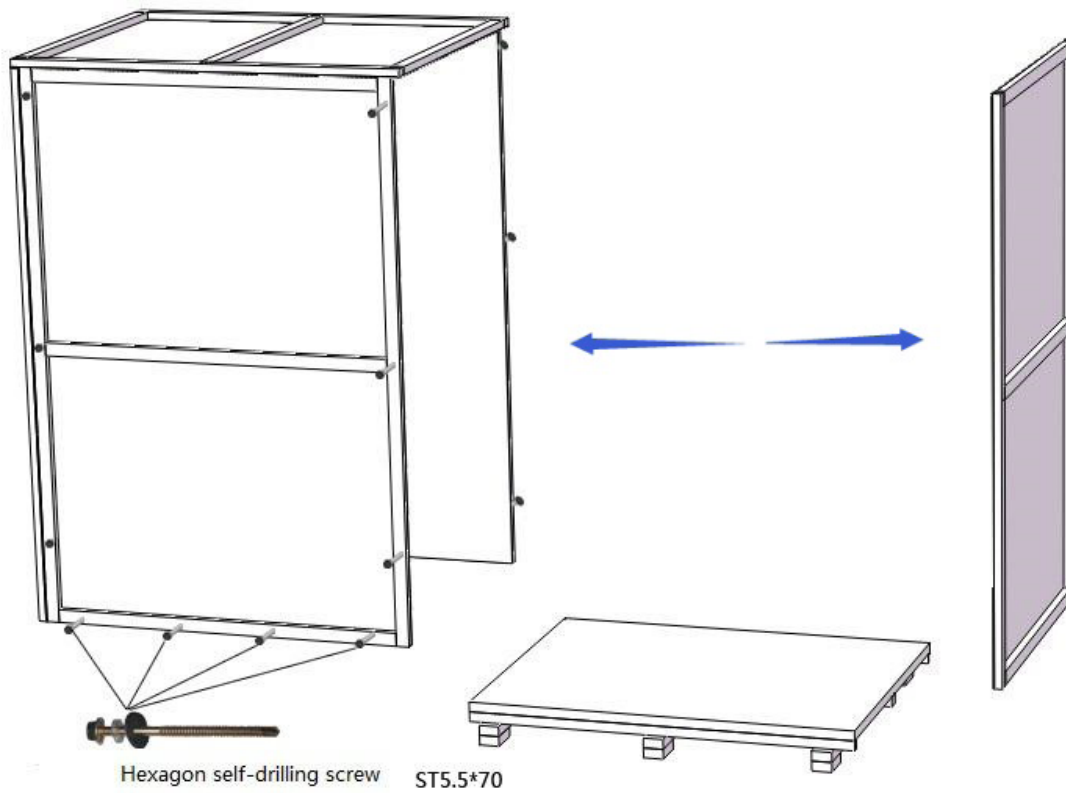

Picture 3

1.2 Accessories checking

Items	Quantity
Main Body	1unit
Base Stand	1 set
External exhaust blower	1set
External exhaust blower holder	1set
Exhaust duct	1pc
Exhaust duct clip	2pc
Power cord	1pc
Fuse (15A)	2pcs
Fuse (5A)	1pc
UV Lamp (T6 40W)	1pc
Remote control (including battery)	1pc
Keys	2pc
Foot switch	1pc
User manual	1pc
Drain Valve	1set
Inner hex cylinder head bolt M10×55	1pc
Inner hex cylinder head bolt M10×80+flat washer 10+spring washer10+M10 nut	4sets
Inner hex cylinder head bolt M10×25+flat washer 10+spring washer 10	4sets
Inner hex cylinder head bolt M8×25+flat washer 8+spring washer 8+ M8 nut	4sets
Inner hexagon wrench	1pc
Big rubber gasket	1pc
Small rubber gasket	1pc
Front window tubular motor control rod	1pc
M8*100 Expansion bolt	6pcs
Transparent glass glue (with rubber mouth)	1pc
Buckle stopper (white)	7pcs
Connecting fittings	4pcs

1.3 Installation conditions and using environment

To avoid disturbances to the safety cabinet and its operator, follow the following guidelines, while determining a suitable location for the cabinet:

- a. The distance from the plane of the aperture to any circulation space should be at least 1000 mm, so as to preserve a zone undisturbed by anyone other than the operator.
- b. Biological safety cabinets should be placed in a position where there should be no opposing wall (or other obstruction likely to affect the airflow) within 2000 mm of the front aperture.
- c. Safety cabinets should not be installed in positions where they are likely to be affected by other items or equipment. In particular the distance to the aperture of an opposing safety cabinet, fume cupboard, or the edge of a local exhaust ventilation outlet should not be less than 3000 mm.
- d. Any room air supply diffuser should not be within 1500 mm of the front aperture.
- e. Doorways should not be within 1500 mm of the aperture or within 1000 mm of the side of the safety cabinet.
- f. The position of a safety cabinet should satisfy the spatial requirements (e.g. vision, lighting and convenience of access) of the operator and personnel working nearby. When a cabinet is installed on a bench top, the leading edge should be flush with or slightly overhanging the edge of the bench top.

Working environment:

- (1) Only is suitable for indoor;
- (2) Ambient temperature: 15°C~35°C;
- (3) Relative Humidity: ≤75%;
- (4) Atmospheric pressure range: 70 kPa~106 kPa;
- (5) Electrical parameters: Consistent with the rated voltage of the biosafety cabinet (See 2.1.5 technical parameter performance index);
- (6) Power supply need to be grounded; (Judging method: testing the fire wire and the zero line of the power supply with multimeter, the fire wire to ground voltage should be grid voltage and the zero line to ground voltage should be 0, otherwise the power supply ground is bad).

1.4 Installation

- a. Remove all the package materials;
- b. Inspect the surface of main body to make sure whether there is scratch, deformation or uncorrelated things;
- c. Move the whole device to the final installation location;

 The base stand will be packed at back of main body, please take it out before installation. DO NOT INVERT, DISASSEMBLE OR TILT THE CABINET during transportation.

d. The base stand assembly

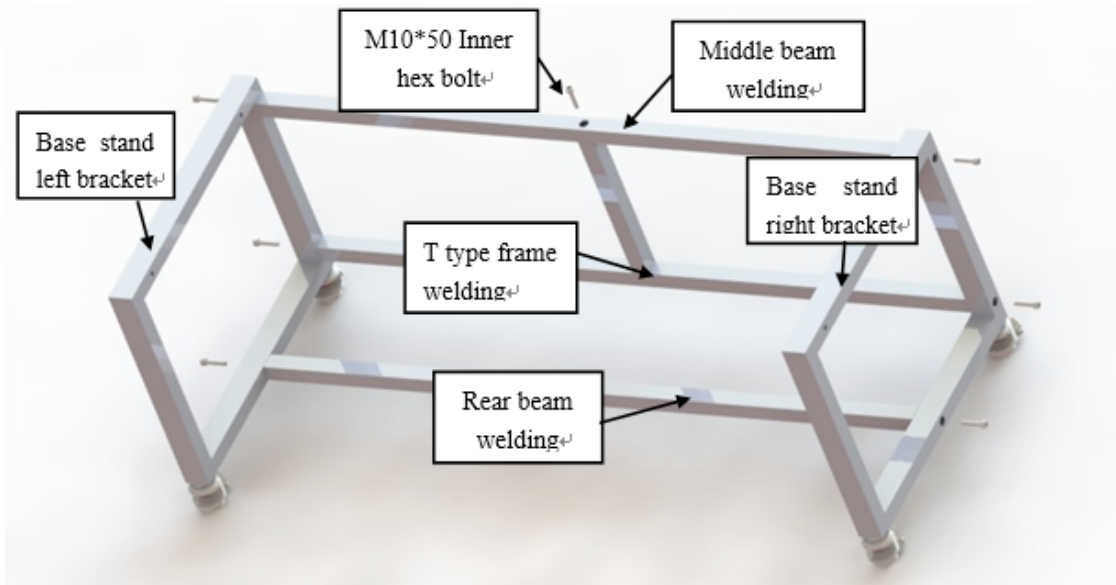

Picture 4

Remove the M10×55 Hexagon socket head screws, Buckle plug, referring to Picture 4 assembled base, firmly fastening requirements.

d. Connect base stand and main body

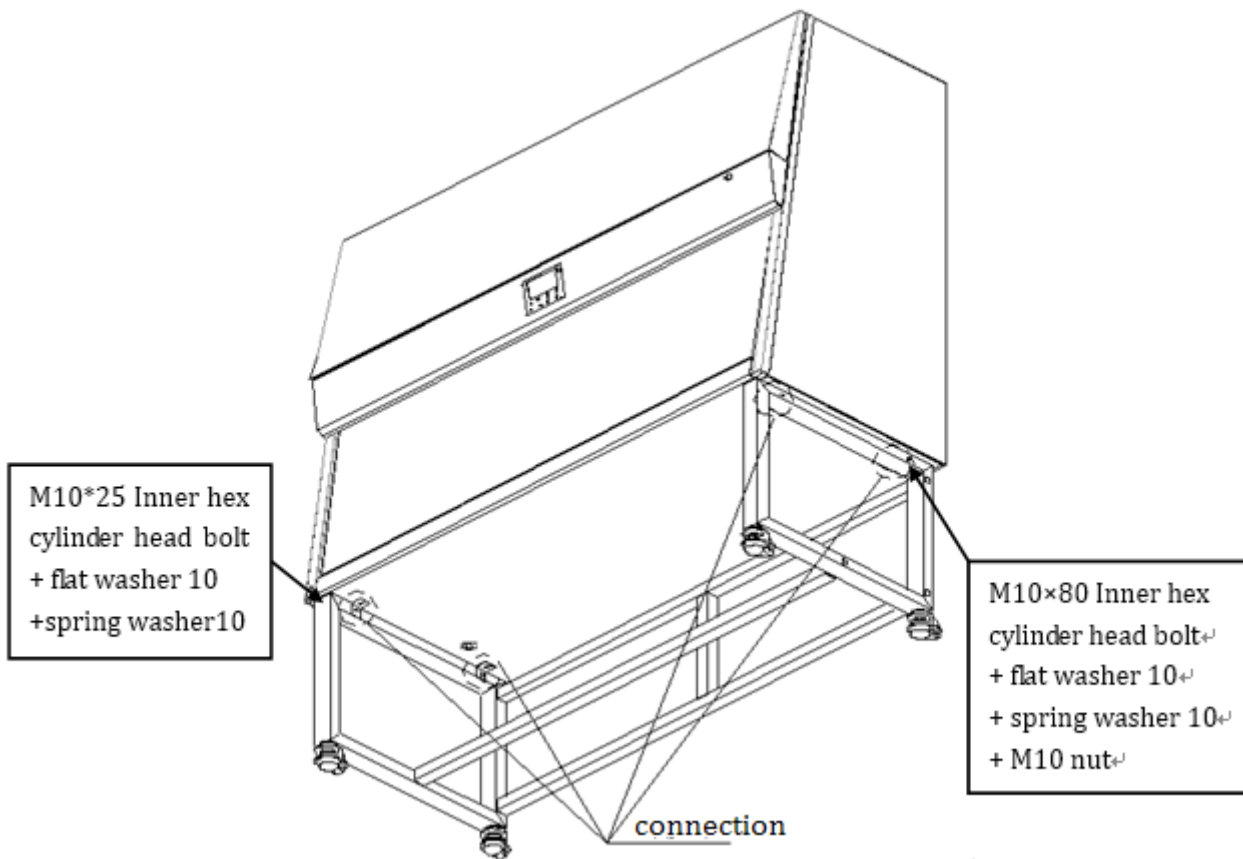

Picture 5

Take out the M10x80 Inner hex cylinder head screw + Flat washer 10 + Spring washer 10 + M10 nut, M10x25 Inner hex cylinder head screw + Flat washer 10 + Spring washer 10 and Connecting fittings 4 pcs from the accessory box, fasten tightly according to Picture 5.

f. Installation of Drain valve

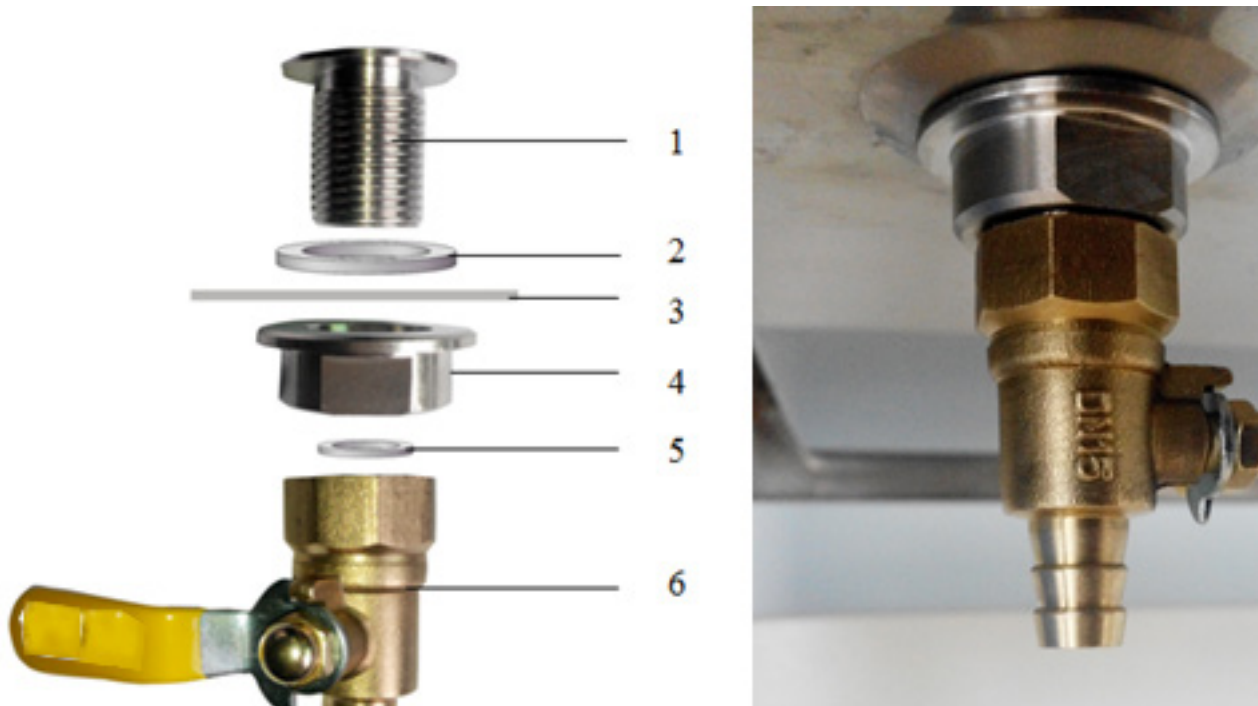

Picture 6

1. Drain valve connector
2. Shim (Inner diameter*outer diameter*thickness $\Phi 20*\Phi 28*2\text{mm}$)
3. Safety cabinet bottom installation holes
4. Ball coupling fastening nut
5. Rubber gasket (Inner diameter*outer diameter*thickness $\Phi 13*\Phi 19*2\text{mm}$)
6. Drain valve

Take out Drain valve connector, Shim, Ball coupling fastening nut, Rubber gasket, Drain valve, assembling from up to down as Picture 6 illustrated.

g. Adjustment of Footmaster Caster

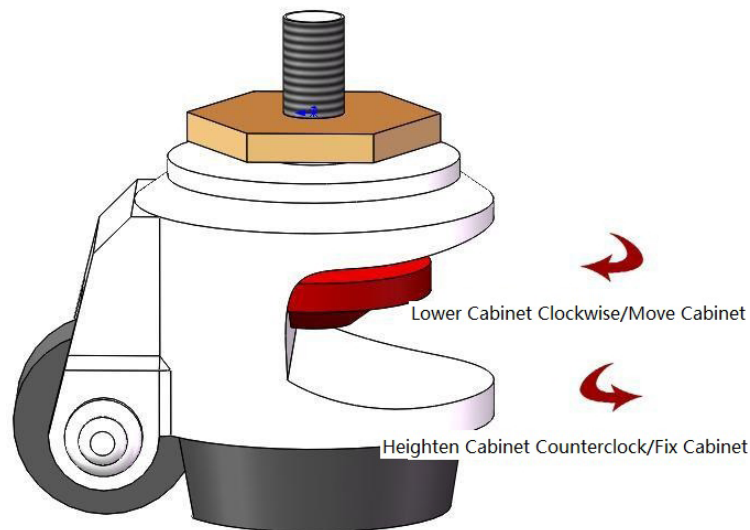

Picture 7

Clockwise rotate caster' red part to low down the base feet and the height of the cabinet. Low down all four casters can move the cabinet position. Counterclockwise rotate casters' red part can rise the base leg and height of cabinet. Raising all four casters at same time can fix the cabinet. Adjust the four Foot -masters makes the cabinet stable.

h. Foot Switch

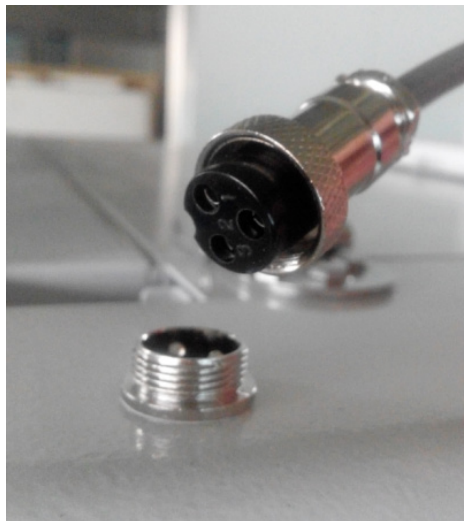

Picture 8

Install Foot Switch as Picture 8. It's socket is at the left top, connect the plug.

i. Installation of Water and Gas Tap (Optional)



Picture 9

1. Fastening Nut
2. Stainless Steel Water and Gas Taps

Take out fastening nuts, water and gas taps, installing as Picture 9.

j. Installation of External exhaust blower

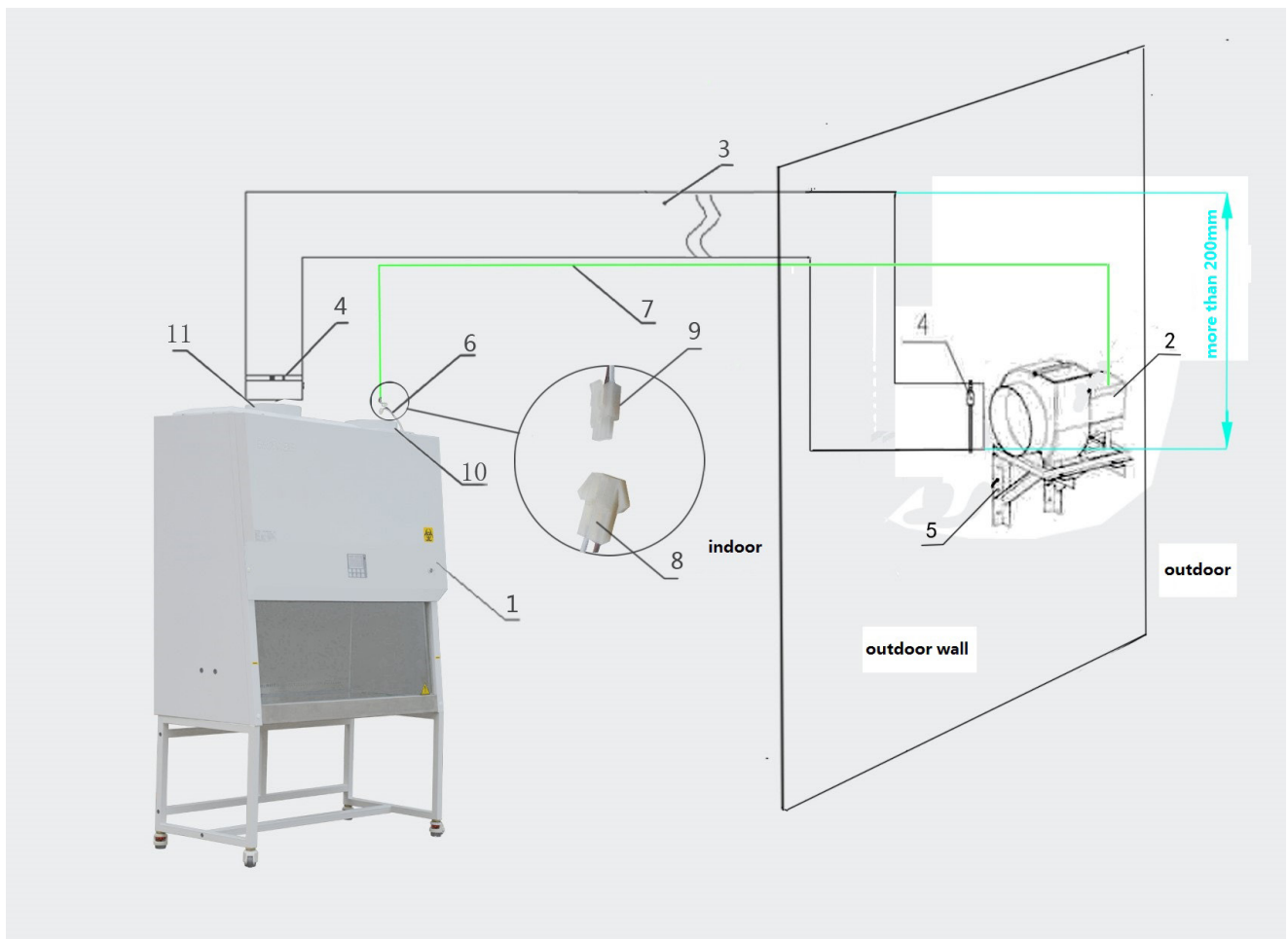

Picture 10

1. Main Body 2.Exhaust blower 3.Exhaust duct 4.Exhaust duct clip 5.Exhaust blower mounting bracket 6.Butt plug 7. Blower control line 8. Exhaust blower control line interface 9.Exhaust blower control line socket 10. Air feeding 11.Air exhaust

Installation steps:

- (1) Place the main body in the original location after it is connected with base stand.
- (2) Installation the exhaust blower mounting bracket on the outdoor wall (must be solid wall) near the biosafety cabinet, (Please carefully check the mounting holes on the exhaust blower when installing the two exhaust blower brackets). Using the expansion bolt to fix the exhaust blower mounting bracket onto the outdoor wall.
- (3) Installing the exhaust blower on the exhaust blower mounting bracket by using the hexagon head bolt M8*25, flat washer 8, spring washer 8, M8 screw nut (Professional installation personnel should operate for ensuring safety).
- (4) Remove the duct, one end set into the exhaust duct clip to connect the main body as shown in picture 10, tighten exhaust duct clip.

(5) Remove the other end of the duct out, set into the exhaust duct clip to connect the exhaust blower air inlet as shown in picture10, tighten exhaust duct clip.

(6) Put the exhaust blower control line along the pipeline into indoor, connect the exhaust blower control line socket with the exhaust blower control line interface.

 (1) The duct hole center connected to the exhaust blower must be below the max point center of duct at least 200mm, in order to avoid water or debris along the duct into the main body damaging filters, fans and other internal components.

(2) Please make sure that the main power is off when connecting the exhaust blower control line.

(3) The customer should have the installation conditions, and reserve exhaust duct hole.

(4) The standard duct is 4.3 meters, the installation is not allowed to appear a lot of bending.

(5) Because this biosafety cabinet is a full exhaust type, installation site need to fill air, fill air volume is 1650 m³/h.

1.5 Checking after installation

First, make sure the Voltage and frequency to be same as showed in nameplate, and then check the follows items with power on:

Checking Items	Normal situation
Wind speed display	Inflow 0.53 ± 0.025 m/s , downflow 0.33 ± 0.025 m/s
Pressure display	exhaust filter 120-130Pa, downflow filter 80-110Pa
Fan running	Normally
Fluorescent lamp	Lamp lights after pressing button
UV Lamp	Lamp lights after pressing button
Display screen buttons	All buttons can be used
Socket	Press the socket key, multimeter testing output supply voltage
Foot Switch	Red pedal for glass up, black pedal for glass down

02 User Instructions

2.1 Functions

2.1.1 Product Concept

This products belong to Class II B2 biological safety cabinet, it is a kind of negative pressure filtration system for protecting operator, the laboratory environment and work materials, the front opening which air flow inward have protection function for operator, the filtered laminar flow generated by vertical HEPA can protect work materials, what's more, the polluted air flow become pure after processed by HEPA(ULPA) filter. When it's used in microbiology experiment environment filled with volatile or toxic chemical and radionuclide, suitable exhaust hood in function have to be linked.

2.1.2 Application Range

Biological Safety Cabinet is necessary equipment in the laboratory in the search of microbiology, biomedical, DNA recombinant, animal experiment, and biological products, especially in the occasion that operator need to adopt protective measure, such as medical and health, pharmacy, medical research. Our equipment provides a safety working environment which don't have bacterial and dust in the process of bacterial culture.

2.1.3 Working theory/Air flow pattern and protected area

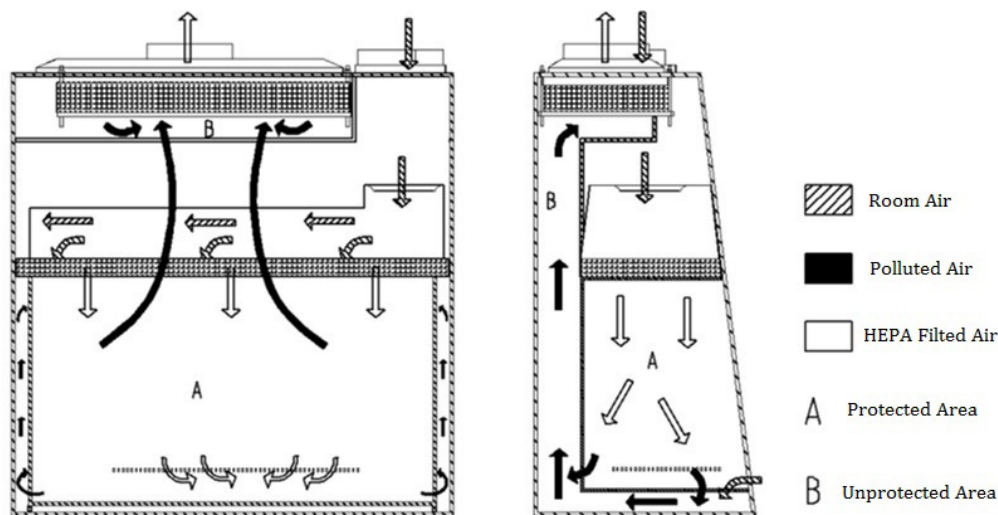

Picture 11

2.1.4 Protected objects

Biological safety cabinets are designed to protect the operator, the laboratory environment and work materials from exposure to infectious aerosols and splashes that may be generated when manipulating materials containing infectious agents, such as primary cultures, stocks and diagnostic

specimens.

2.1.5 TECHNICAL PARAMETERS

Parameters	BCBS-404
Power Supply AC	220V±10% ; 110V±10%
Frequency	50 Hz ; 60Hz
External Size(W*D*H)	1820×750×2250 mm
Working Zone Size(W*D*H)	1670×600×660 mm
Consumption	1200W
Total Airflow Volume	1650m ³ /h
UV Lamp Consumption	40W*2
Fluorescent lamp Consumption	40W*2
Downflow Velocity	0.33±0.025m/s
Inflow Velocity	0.53±0.025m/s
HEAP Filter	99.999 (Diameter: 0.3µm)
Noise	EN12469 ≤58dB / NSF49≤61dB

Notes: (1) Electric consumption power including power which operation area needs to load (Loading no more than 500W)

(2) Our company has right for changing the products, if we need to change and re-design, without prior notice.

2.1.6 Performance Index

1) Biological safety functions

Personnel protection, microbial colony count ≤5CFU;

Sample protection, microbial colony count ≤5CFU;

Cross contamination protection, microbial colony count ≤2CFU.

2) Leak-proof Cabinet

If cabinet pressurized to 500Pa, the pressure should be no less than 450 Pa after 30 min.

3) Integrity of HEPA Filter

Scan and detect the HEPA filter, the leakage rate at any point should not be >0.01%.

Can't scan and detect the HEPA filter, the leakage rate at any point should not be >0.005%

4) Vibration amplitude

The net vibration amplitude between frequency 10Hz and 10KHz is no more than 5 μ m(rms).

5) Illumination

The average illumination is no less than 650 lux, each illumination measured values is no less than 430lux.

6) Mechanical performance

Structure design is reasonable, high quality materials are adopted for the cabinet.

It can resist shape global deformation caused by external force.

The working surface will not occur permanent deformation when weight put reaching 23kg.

7) Electrical properties

The voltage increases to 1390V(AC) in 5s and keep for another 5s without breakdown.

Grounding resistance $\leq 0.1\Omega$

2.2 Product structure

2.2.1 Structural composition

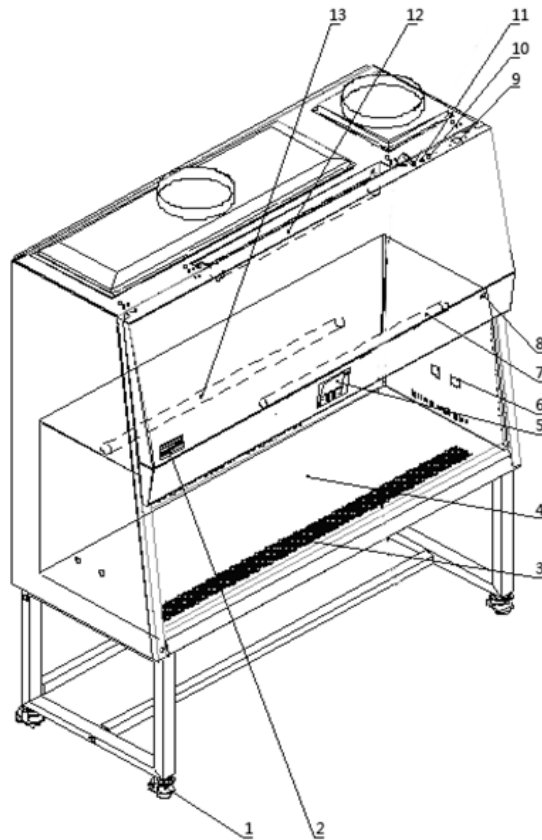

Picture 12

1. Footmaster Caster
2. Nameplate
3. Inflow grid
4. Front window
5. Control panel
6. Water-proof socket
7. Fluorescent Lamp
8. Power supply lock
9. Power socket
10. Main power fuse tube
11. Blower fuse tube
12. Tube motor
13. UV lamp

2.2.2 Structure introduction

1) Driving System of Front Window

Driving system consists of tube motor, front window, hauling sash and position switch.

2) Air Filtration System

Air Filtration System is the most important system of BSC. It consists of blower, supply filter and exhaust filter. The function of Air Filtration System is transferring filtered air to work area, ensure the down flow velocity, and keep Class 100 cleanness of work area.

3) UV Light

UV lamp is inside work area. So UV lamp can well sterilize all space of work area.

4) Fluorescent Light

The BSC is equipped with H type energy-saving fluorescent lamp. It can make sure average illumination inside work area which meets standard requirements.

5) Air pipe

Air pipe is the ventage of differential pressure sensor.

 The air pipe should not be blocked and please do not hang anything on the pipes, otherwise it will effect wind speed and pressure.

6) Power lock

When the power cord is connected to main power, switch the key for power lock, then the equipment is powered on.

7) Water proof Socket

Waterproof Sockets are located on the right side of the work area, which can be controlled by SOCKET button.

- ⚠ (1) Please make sure the total load of sockets should be $\leq 500W$;
- (2) Waterproof socket can be waterproof only when the front cover is put down.

8) Fuse

The equipment is equipped with main power fuse, waterproof socket fuse and fan fuse. They are located near the power cord's outlet. Fuse label is corresponding to the relevant specifications. Please refer to 3.2.

9) LCD Display (Liquid Crystal Display)

LCD display (Liquid Crystal Display) is that place the liquid crystal in the middle of two pieces of parallel glass, there are many small vertical and horizontal wires in the middle of the two pieces of glass, control the rod-shaped crystal molecules to change direction through energization or not, the light refracting out produce images, low power consumption, no electromagnetic radiation.

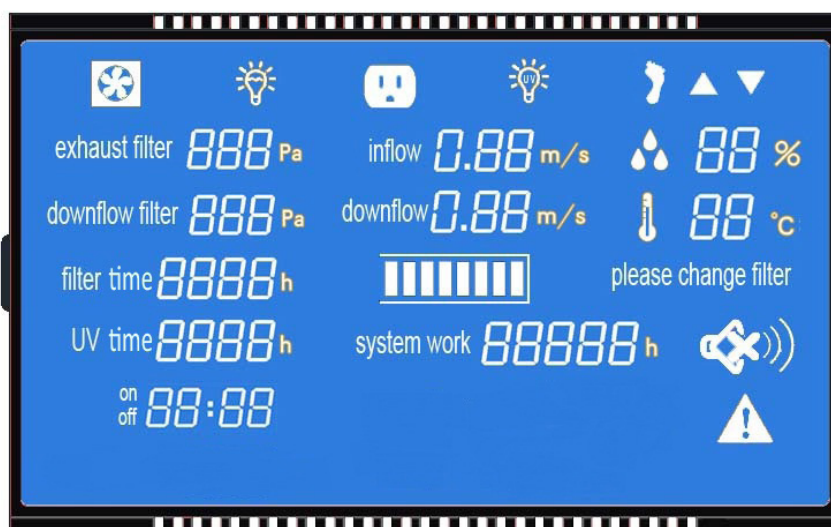

Picture 13

Large LCD display indicates detailed key parameters, it is real-time display to reflect the equipment working condition, such as effective working state of the filter, which is more intuitive.

10) Control of Front Window

Front window is motorized, panel soft touch button can control freely, without contacting with the glass doors and windows directly. Glass door control motor is a dedicated reversible speed regulating motor, has the characteristics of big start torque and rotation stability.

11) Structure

- a) Biological Safety Cabinet's both sides and back area are negative pressure air channel. And the negative pressure keeps work area away from contamination.
- b) Cabinet body is built of 1.2mm cold-rolled steel with anti-powder coating. Strong and steady.
- c) Work area is fully made of 304 stainless steel which looks beautiful and with corrosion resistance performance.
- d) Base stand is made of cold-rolled steel with anti-powder coating.
- e) Soft touch type control panel, easy to handle and beautiful appearance.

2.3 Control panel

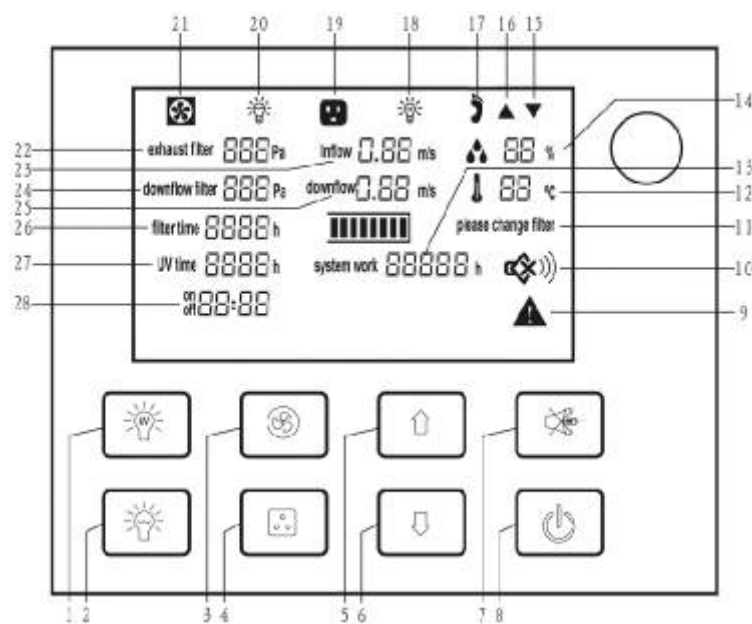

- | | |
|----------------------------|--|
| 1. UV Lamp | 15. Glass Window Down Status |
| 2. Fluorescent Lamp | 16. Glass Window Up Status |
| 3. Blower | 17. Foot Switch Status |
| 4. Socket | 18. UV Status |
| 5. Glass Window Up | 19. Socket Status |
| 6. Glass Window Down | 20. Fluorescent Lamp Status |
| 7. Mute | 21. Blower Status |
| 8. Power | 22. Exhaust Filter Differential pressure |
| 9. Alarm Status | 23. Inflow Velocity |
| 10. Mute Status | 24. Supply Filter Differential pressure |
| 11. Filter Changing Status | 25. Downflow Velocity |
| 12. Temperature | 26. Filter working time |
| 13. System Working Time | 27. UV Lamp working time |
| 14. Humidity | 28. Reservation timing |

a) LCD Screen

The working status of the equipment and operation can be seen on the LCD screen.

b) Soft touch button.

Main functions could be executed by touch-buttons.



: The power button



: To control fluorescent lamp



: To control UV lamp.(It works only after front window fully closed.)



: To control blower working status. (It will not work when front window is fully closed.)



: To control socket power status.



: Press MUTE button to stop voice prompt



: Press UP button, glass window will raise.



: Press Down button, glass window will fall down.

There are totally 8 common button on control panel.

Clock Adjustment:

Turn the power key, so machine is in standby state.

Press the light button, and then press the power button for 5 seconds. Then you see the state of clock adjustment after a buzzer alarm.

Firstly, minute position is flashing, press UP and DOWN to adjust to present time. Then press the MUTE button switching to hour position and adjust to present time. After that, press the light button first, and press the power button for about 5 seconds. Data will be saved after a buzzer alarm.

2.4 Remote Control & Foot switch

2.4.1 Remote control

It is inconvenient for the users to operate from a distance. Small & light remote control is flexibly to be used to control all the functions of the cabinet in a distance $\leq 6\text{m}$, 30° range. The operator can even carry it with themselves during experiment for convenience.

This remote control adopt specific chip which is featured with good anti-jamming performance, longer control distance and high control precision.

Buttons of Remote Control:

1. Power (POWER)
2. Reservation Time (SUB)
3. Timer (INSTALL TIMER)
4. Confirm (CONFIRM)
5. Cancel (CANCEL)
6. Turn up (+)
7. Turn down (-)
8. Fan (FAN)
9. UV (UV)
10. Illumination (LIGHT)
11. Socket (SOCKET)
12. Mute (MUTE)
13. Front window up (UP)
14. Front window down (DOWN)

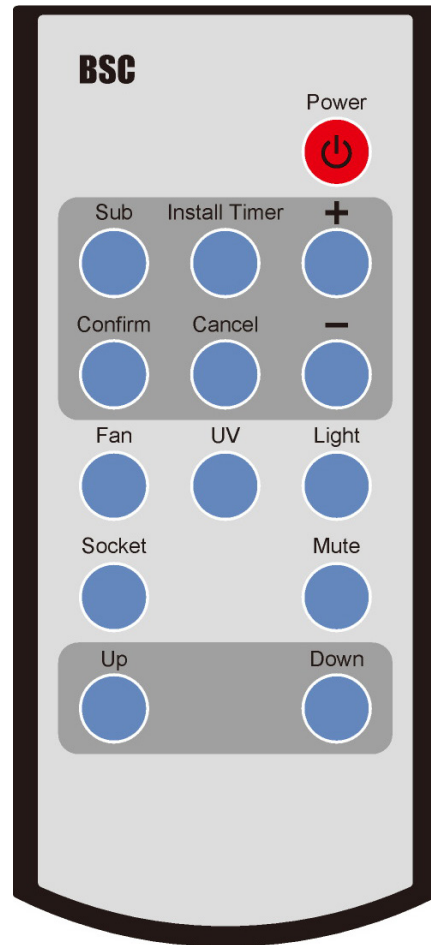

Picture 1

Remote Control

A. Reservation Time (SUB)

- a. Connect power, open power lock, and press the reservation timing button (SUB);
- b. Adjust the time (minutes) by "+" or "-" button. Press the confirmation button (CONFIRM) to confirm; and then adjust other minutes and hours position data in the same way;
- c. After the time is confirmed, the corresponding display lamp lights by selecting the function buttons (such as UV);
- d. Press the POWER button again, the reservation function starts. Reserved time starts count down. The corresponding setting function starts when the time counts down to zero.

B. Timer (INSTALL TIMER)

- a. Connect power, open power lock, press button (POWER), the corresponding display lamp lights by selecting the function buttons (such as UV);
- b. Press button (INSTALL TIMER), adjust the time (minutes) by "+" or "-" button. Press button (CONFIRM) to confirm; and then adjust other minutes and hours position data in the same way;
- c. After the time is confirmed, the Timer function starts. When the time counts down to zero, all the functions will be off, the cabinet will be in standby mode.

C. Application of Reservation Time

Biological safety cabinet is equipped with special UV lamp. When turning on or turning off the cabinet, sterilization time of UV lamp should be at least 30 minutes. In order to save the waiting time of turning on or turning off the cabinet, we develop reservation time function. It realizes function of automatic turning on or turning off the cabinet after the sterilization finished. Reservation time setting range is from 0 to 99 hours and 59 minutes. This function helps operators to save time and improve efficiency.

2.4.2 The use of foot switch



Picture 2

Press the left red switch by foot, front window goes up, press the right black switch, front window goes down.

2.5 Instructions for Operation

2.5.1 Normal Operation Notice

- (1) Make sure input voltage is correct and stable. The rated load of main power socket should be higher than cabinet consumption. Plug must be well grounded.
- (2) In order to avoid air turbulence, the operator should slightly move his arms during experiment. Hands should stay inside the working area at least 1 minute before operating. In order to decrease the times of arms moving into and out of the working area, prepare all the necessary items inside the cabinet before starting experiment;
- (3) Moving principles of different samples inside cabinet: When two or more samples need to be moved, be sure that low-polluting samples move to high-polluting samples. Movement of items should also follow the principles of slow-moving.
- (4) Samples placed in parallel: Samples should be placed in the cabinet parallel to avoid cross-contamination between samples and blocking back air grille.
- (5) In order to avoid samples being sucked into the negative passage or the blower, do not place soft and slight samples (for example: soft tissue) on the surface during experiment;
- (6) The weight of items placed in the cabinet should be no more than 23Kg/25×25cm²
- (7) Avoid vibration: avoid using vibration equipment (eg centrifuges, vortex oscillator, etc.) inside the

cabinet. Vibration would cause lower cleanliness of operating area and affect operator protection.

(8) No flame: No flame is allowed inside the cabinet. Using of fire will lead to airflow disorder, and filter damage. If sterilization is required during the experiment, infrared sterilizer is highly recommended.

(9) HEPA filter life: With the usage time increasing, dust and bacteria accumulate inside HEPA filter. Filter Resistance is getting bigger, when it reaches the maximum point, there will be audible and visual alarm. Please replace new HEPA filter, otherwise it will affect the safety performance of the equipment. The used filter should be processed as medical waste.

(10) There is a negative passage surrounding the work area, which is sealed strictly in the factory. The operator is not allowed to remove or loose screws of those parts. If necessary, please contact service personal.

(11) Front Grille is used for air intake and drain. Do not block it, otherwise it will affect airflow. Armrest is recommended to solve this problem and reducing the operator's wrist fatigue.

(12) Long-term use of biological safety cabinets will inevitably cause pollution (e.g. HEPA filters, corner cabinets, etc.). In order to sterilize thoroughly every 500 hours, formalin (formaldehyde) fumigation sterilizer is recommended. After sterilization, neutralize formaldehyde gas with ammonium hydrogen carbonate. Make sure no sterilization gas escapes during the whole process.

(13) The maximum storage period is one year. If the period is more than one year, performance test should be done.

Serious declaration: we will take no responsibility for risks caused by improper operation and man-made damages!

2.5.2 Operation Process

a. Connect the same power reply, as required of equipment

b. Open the power lock, LCD display lights up and alarm rings at the same time, then the machine enters to standby status. Waiting for the operator to input button to use it.

c. Press POWER button, then the following functions are available: Fluorescent lamp, UV lamp, Fan, Mute, Sockets, Front window up and down, Reservation timing.

⚠ When front window is closed and fluorescent light is off, then press the UV button to select the sterilization function.

d. Before doing experiment, please sterilize the cabinet for more than 30 minutes by UV lamp.

⚠ (1) For safety of eyes and skin, people should leave room during the UV sterilization.

(2) UV lamp intensity should be tested regularly. If there is no test conditions, it should be replace when the UV timer on the display indicate the working time reaches to 1000 hours.

e. Please move the front window at 200mm height from the work table, turn on the fan, make sure the experiment should be started after fan working for at least half an hour.

⚠ For operating safety, please put testing materials inside the cabinet in advance, and keep the front window at 200mm height from the work table during operation.

After finishing the experiment, please move the front window down to the bottom, and make sure to sterilize the cabinet by UV lamp for 30 minutes before turning off the cabinet.

2.6. Daily maintenance

Because the operating time will directly affect the judgment of maintenance needs, we recommend the user keep a detailed record of operating time for reference.

 When doing maintenance, please pay attention to cut off the power, so as to avoid electric shock!

2.6.1 Preparations before maintenance

Soap, hot water or warm water, a soft cotton cloth, dry cloth or towel, medical alcohol or other disinfectants, 100 dilution of household bleach, abrasive household cleaners, sterile water

2.6.2 Clean the cabinet surface

1) Clean the operating area surface

Wipe the entire surface with a soft cotton cloth or towel soaked with concentrated liquid soap, then wipe up the soap with another cotton cloth or towel soaked with clean hot or warm water, and then wipe the surface with a dry cotton cloth or towel rapidly.

For the contaminated or dirty work surface or sump., use 70% medical alcohol or other disinfectant to wipe.

Disinfectants used for wiping should not damage 304 stainless steel.

2) Clean the external surface and front window.

Use soft cotton cloth or towel to wipe the surface with non-abrasive household cleanser.

2.6.3 Overall maintenance period

We suggest comprehensive maintenance period is one year or 1000 working hours.

2.6.4 Maintenance methods

1) Daily or weekly maintenance

- a. Disinfect and clean operating area;
- b. Clean the external surface and front window around the operating area;
- c. Check the various functions of equipment;
- d. Record this maintenance result

2) Monthly maintenance

- a. Clean the external surface and front window.
- b. Wipe the working table, inner wall surface of operating area (excluding the wind distributing grid of operating area) and the inner surface of glass door with 70% medical alcohol or household bleach diluted 1:100 (i.e. 0.05% sodium hypochlorite). Then wipe again with sterile water in order to eliminate the rest chlorine.

c. Check the various functions of equipment;

d. Record this maintenance result;

3) Annual maintenance

a. Check the two conveyor belts of front window drive unit, and ensure that their tightness is coincident.

b. Check the UV lamp and fluorescent lamps.

c. Apply for testing the overall performance of cabinet on an annual basis to ensure the performance safety. User is responsible for testing costs.

d. Record this maintenance result.

2.6.5 Storage conditions

Safety cabinet should be stored in a relative humidity no more than 75%, the temperature is below 40°C, in the warehouse with good ventilation performance, no acid, no alkali and no other corrosive gases, storage period shall not exceed one year, safety cabinet for more than a year needs to be unpacked and checked. Only the tested and qualified safety cabinet can be sold.

Methods and procedures for disinfection

Details in the After-sale service manual

Disinfection is necessary when any contaminated part of the biosafety cabinet needed for routine maintenance, replacement filters, and performance testing, etc. Before doing certification test and gas sterilization, all internal working surface and the exposed outer surface should be disinfected with a suitable disinfectant.

Replacement parts list:

Number	Name	Specification
B01	Fuse	10A
B02	Fuse	5A
B03	Lamp holder T8	LG13-01A
B04	H type lamp holder T5	GZ243L3 T160 0.5-1°
B05	UV Lamp	T6 40W
B06	H type fluorescent lamp	T5 40W
B07	UV lamp ballast	1*TL8-36W
B08	Fluorescent lamp ballasts	2*TL5-40W
B09	Lower filter (Supply filter)	1700*470*69mm
B10	Upper filter (Exhaust filter)	1300*430*80mm
B11	Fan	R4E355-AK05-05
B12	External exhaust blower	YF12-50No3.0A

B13	Control panel	LCD control board (strong circuit board, weak circuit board, display screen)
B14	Remote control (with battery)	
B15	Key selection button	LA42Y2-20B
B16	Glass	1758*720*6.38mm
B17	Foot switch	

2.9 Wiring diagram

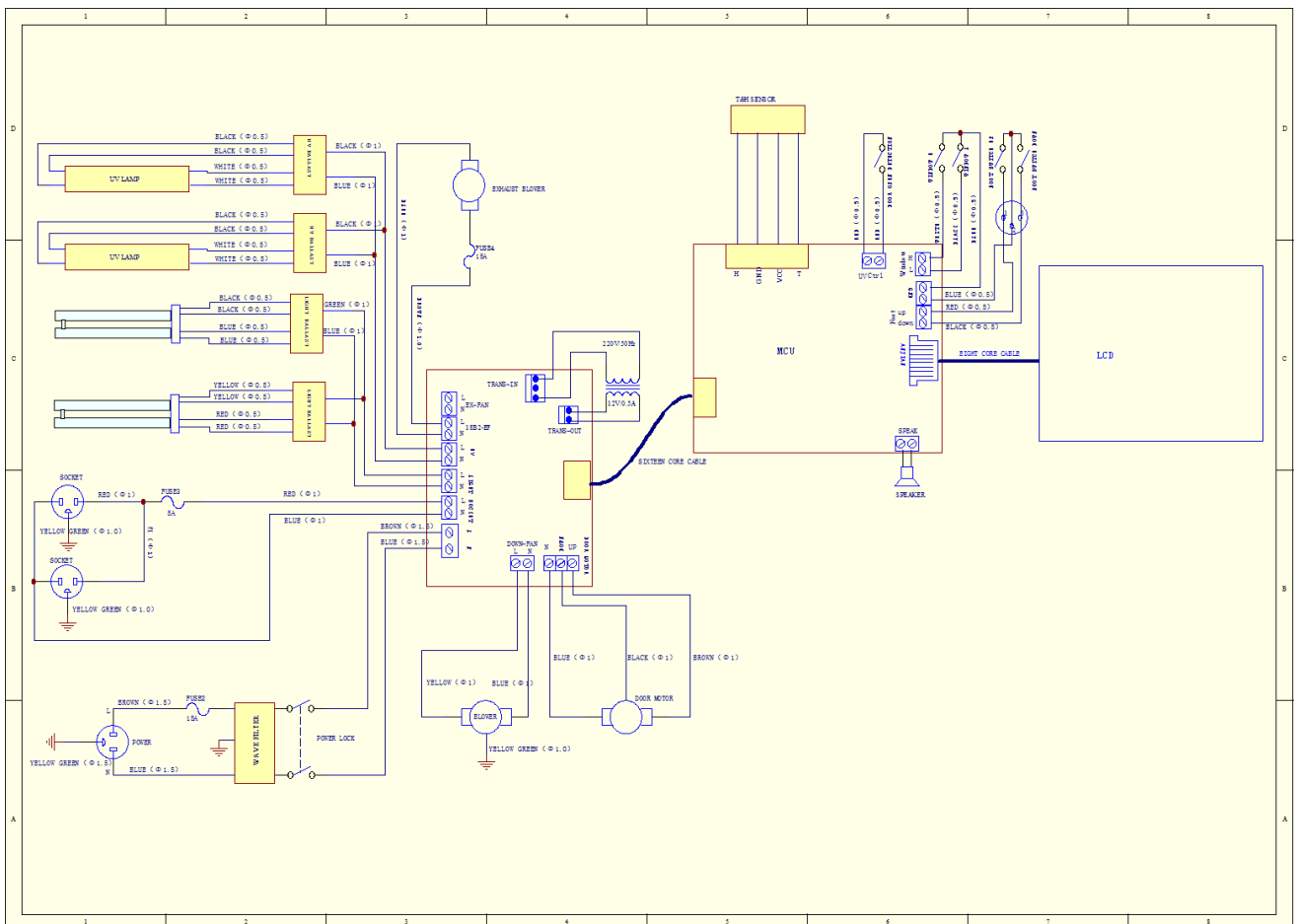

Picture 3

03 Trouble shooting and Labels

3.1 Common faults & solution

3.1.1 Warning and reminder

Digital display of pressure difference, digital velocity display, audible and visual alarm system.

1) Over safety height alarm for front window

There will be audio and visual alarm when front window is lifting over safety height. Same time LCD display will light exclamation mark. Then just adjust the height of the front window.(Front window height setting value is 200mm).

2) HEPA filter pressure difference alarm

There will be audio and visual alarm if pressure of air supply filter or exhaust filter can't meet present value, at the same time LCD display will light exclamation mark. Remind the operator to replace the filter immediately to protect the operator's safety.

3) Velocity fluctuation alarm

There will be audio and visual alarm if the inflow velocity and down flow velocity below 20% of the standard value, namely, inflow velocity below 0.42m/s, down flow velocity below 0.26m/s, at the same time LCD display will light exclamation mark to remind the operator pay attention. When the inflow velocity is below 0.42m/s, the fan will stop working at the same time sound and light alarm, the fan will be started until when inflow velocity is above 0.42m/s.

3.1.2 Trouble shooting

Please confirm whether the power is connected or not, whether the power cord is obvious damaged or not, whether the fuse is good or not, and whether the power locks are in the open state or not before the fault diagnosis.

Faults	Check parts	Measures
Fluorescent lamp doesn't work	Lamp holder	Tube and lamp holder is connected securely
	Circuit	Check circuit
	fluorescent tube	Change it
	Ballast	Change it
	Control panel	Change it
UV lamp doesn't work	Front window, fluorescent lamp and blower	Check the front window, fluorescent lamp and the blower is open or not.
	Lamp holder	Tube and lamp holder is connected securely.
	Circuit	Check circuit
	UV lamp	Change it
	Micro Switch	Check if Micro Switch is broken
	Control panel	Change it
Button doesn't work	Control panel	Make sure the power connects well and the fuse is well
		Check if the button is broken
		Make sure the connecting wire is connected well
		Change control panel
Blower doesn't work	Front window	Front window is open or not, blower works only when the front window is open
	Micro Switch	Check if Micro Switch is broken or works fine
	Blower	If blower is broken, change it
	Circuit	Check circuit
	Control panel	Change it
No electricity in socket	Socket fuse	Check if socket fuse is broken
	Socket	Check if socket is broken
	Circuit	Check circuit
	Control panel	Change it

Pressure or air speed displayed incorrectly	Gas circuit	Check whether gas circuit has dropped, is broken, or jammed
	Control panel	Change it
Front window doesn't work	Circuit	Check circuit
	Motor of front window	Check front window motor
	Transmission part	Check transmission connection and lead rail
	Control panel	change it
Foot switch doesn't work	Circuit	Check circuit
	Control panel	Change it
Remote control doesn't work	Remote control	Check if the Remote control is broken or not, and if there's electric in the battery
	Connection cable	Check whether main control panel and display board is connected well.
	Control panel	Change it
No electricity in equipment	Power supply	Check power supply connects well
	Power wire	Check whether power wire has obvious damage
	Fuse	Check if the fuse is good
	Power key	Check if power key is open, is broken or not
	Transformer	Check whether the transformer works normally
	Control panel	Change it
Display doesn't work	Connection cable	Check whether the connection cable is connected well
	Display screen	Check whether the display screen is well
	Control panel	Change it
No alarm	Micro switch	Check whether the micro switch is good, and it works normally or not.
	Circuit	Check whether connection circuit of micro switch is good.
	Control panel	Change it

 NOTES:

- (1) The above electrical parts must be operated by a qualified electrician in safety conditions (cutting off power supply). The other parts are not allowed to remove; otherwise the user should take responsibility by them;
- (2) When failures are not occur, and the operator can't solve, please notify our maintenance department immediately. For your safety, please do not maintain equipment by yourself;
- (3) The maintenance of this equipment is undertaken by trained and recognized technicians;
- (4) If you need to order parts, contact the agent or our technical service department, and please indicate the model and serial number of the cabinet purchased.

3.1.3 Simple accessories replacement

1) Replace the fuse

Socket, fan fuse are located in the top operation panel. When replace them, turn off the power and disconnect plug, use a Phillips screwdriver counterclockwise pressing screwed fuse holder, remove the fuse out and replace a new fuse, and then clockwise pressing screwed fuse holder; FireWire fuse is located in the side of the cabinet operation panel, take out of the fuse holder using a slotted screwdriver and replace with a new fuse, and then press it back.

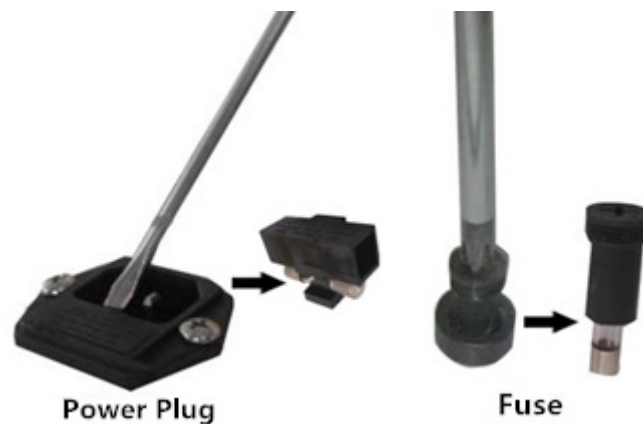

Picture 18

2) Replace fluorescent light

When replacing lights, make sure that the power is off, open the operation panel like shown in Picture 19, use the control panel support frame (fixed in the inside position of the control panel as shown), then like Picture 20 shown removing the lamp tube towards the arrow direction, take the corresponding H type lamp tube, put it to the lamp holder and plug in the opposite direction.

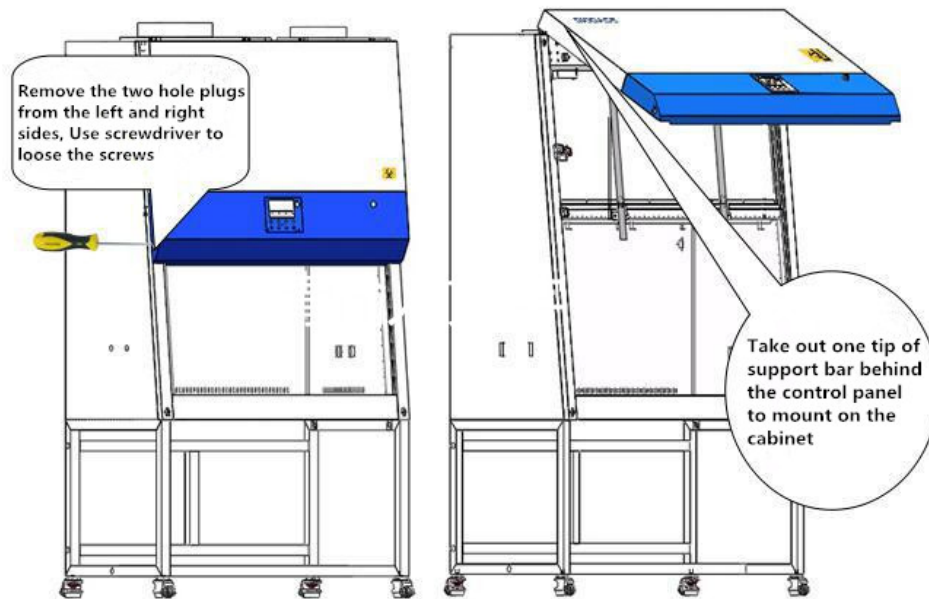

Picture 19

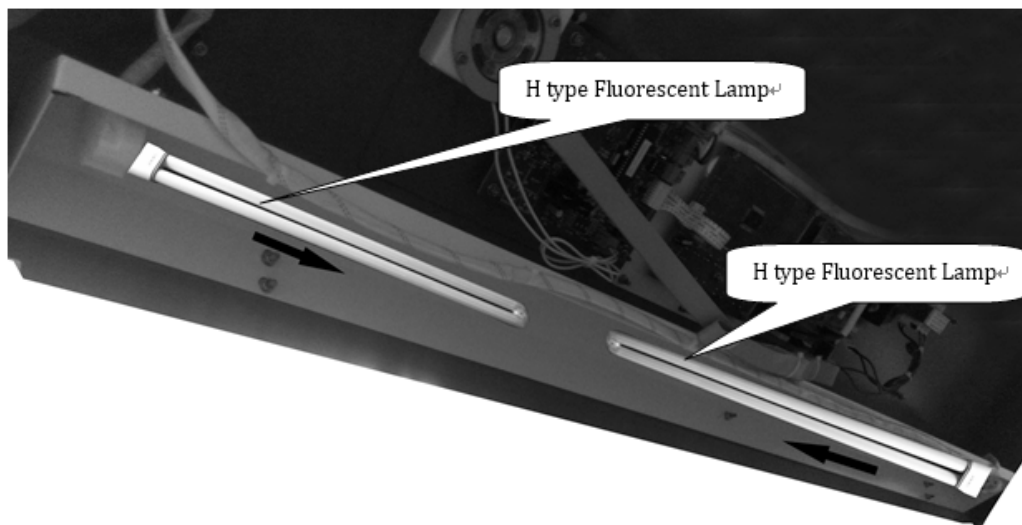

Picture 20

3) Replace the UV lamp

UV lamp should be replaced regularly according to the frequency of use, when using UV lamps reach to the time of 600 hours, we recommend to replace the lamp. When replacing, first make sure the power is off, and then screw the lamp tube 90 ° and take it off , then take the correspondence type of UV lamp, and put it to the lamp holder and screw 90 ° in reverse direction. After replacing the UV lamp, it needs to keep pressing the button of UV for about five seconds when the machine stays standby.



Picture 21

3.2 Label Description

1) Biological hazard label (Picture 22)



Picture 22

2) Fuse label (Picture 23)



a

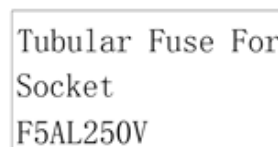

b

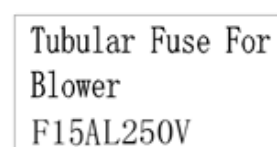

c

Picture 23

Note:

- a. 15A power fuse label
- b. Operating area 5A socket fuse labels
- c. 15A blower fuse label

3) Ground label



Picture 24

4) Glass door super elevation warning label



Picture 25

5) UV lamp alarm label



Picture 26

6) Load requirements label

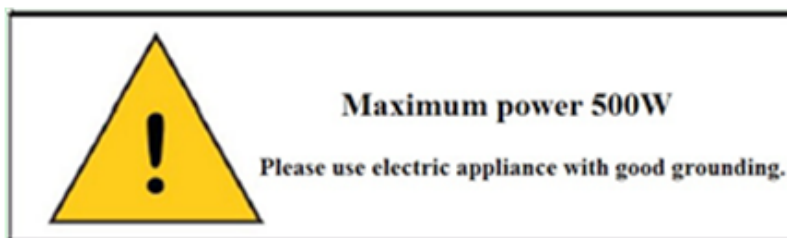

Picture 27

7) Exhaust filter upstream label



Picture 28

8) Downflow filter upstream label



Picture 29

9) Air outlet label

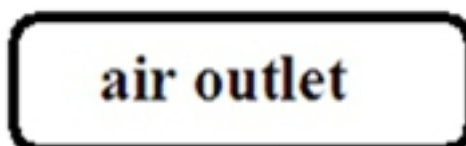

Picture 30

10) Air supply inlet label

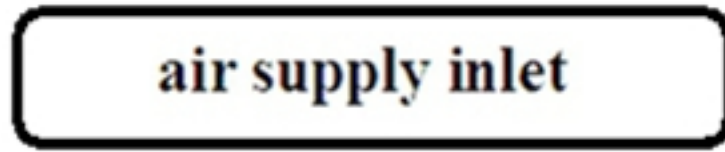

Picture 31

04 Warranty

- 1) Warranty is 12 months from EX-factory date (excluding consumable accessories, UV and Fluorescent lamp, fuse).
- 2) We will take no responsibility for risks caused by improper operation and man-made damages.
- 3) After the expiration of warranty, our company is also responsible for repairs, but the corresponding maintenance cost should be charged.
- 4) Life time of biosafety cabinet is 8 years from production date on the label.
- 5) We can provide equipment drawings and necessary technical data for maintenance companies or personnel trained by our company.



BIOLAB SCIENTIFIC LIMITED
91 Trafford Crescent, Markham, Ontario,
L3R 7J3, Canada

 +1 707 533 1445

 info@biolabscientific.com

 www.biolabscientific.com